



# Clean Lighting Leads to Improved Health in Rural Africa: Field Study and Design of a Dirt-Powered Generator

## Citation

Aiden, Aviva Presser. 2014. Clean Lighting Leads to Improved Health in Rural Africa: Field Study and Design of a Dirt-Powered Generator. Doctoral dissertation, Harvard Medical School.

## Permanent link

<http://nrs.harvard.edu/urn-3:HUL.InstRepos:12407604>

## Terms of Use

This article was downloaded from Harvard University's DASH repository, and is made available under the terms and conditions applicable to Other Posted Material, as set forth at <http://nrs.harvard.edu/urn-3:HUL.InstRepos:dash.current.terms-of-use#LAA>

## Share Your Story

The Harvard community has made this article openly available.  
Please share how this access benefits you. [Submit a story](#).

[Accessibility](#)

## ABSTRACT

Two billion people world-wide use kerosene-burning lamps for household lighting. These lamps produce large quantities of soot. In Chapter 2 of this thesis, I perform a field study examining 230 people in rural Uganda. I show that kerosene lamps are a major source of smoke exposure in the developing world, and that replacing such lamps with solar-powered lights reduces indoor soot levels 17-fold, leading to significant improvements in health within months. This finding is particularly notable because respiratory disease is the #1 cause of death in children under 5 worldwide.

Because solar cells are a challenge to manufacture in the developing world, I next examined the potential of harvesting electrons from soil-based microbes as a source of clean energy. Such devices are known as microbial fuel cells (MFCs); because soil is available everywhere, MFCs can, in principle, be locally constructed all over the world. In Chapter 3 of this thesis, I explore the biology of MFCs, using high-throughput DNA sequencing to demonstrate a role for genus *Pseudomonas* in energy production. I also examine numerous agricultural products available throughout the developing world to determine whether any could serve as a suitable 'feed' for MFC soil. I find that dried animal blood increases MFC energy production 10-fold. In Chapter 4 of this thesis, I design a modular, stackable MFC, demonstrate that it can be easily constructed in rural Africa, and use it to power lights and to charge a cell phone battery.



## **DEDICATION**

*To my family*

## ACKNOWLEDGEMENTS

At the head of all understanding is realizing what is and what cannot be, and the consoling of what is not in our power to change. ~Solomon ben Judah ibn Gabirol

God, grant me the serenity to accept the things I cannot change, the courage to change the things I can, and the wisdom to know the different. ~ Reinhold Niebuhr

I am humbly grateful to all those who have helped me along the path to arrive here, and that clean energy and health are not among the unchangeable things we must learn to accept.

I focus here on my time in medical school, though without a doubt, I stand on the shoulders of giants going back a long ways, and to quote Isaac Newton “if I have seen” then I attribute that vision to those benefits.

Medical school started hard on the heels of my PhD work, and I appreciate the patience and perseverance of my mentors in graduate school who helped me complete my PhD studies and finalize the last paper coming out of my doctoral dissertation during my first year of medical school. I want to thank Miguel Rivera and Bradley Bernstein, as well as my PhD adviser Eric Lander for their support.

I’d like to thank my collaborators on the various projects included in this thesis, including some of the early work that predates these studies.

I’d like to thank Team Léboné: Alexander Fabry, Stephen Lwendo, Zoe Sachs-Arellano, David Moinina Sengeh, and Hugo Van Vuuren who started on the MFC path with me seven years ago, and the original Team Soccket, Jessica Lin, Jessica Matthews, Julia Silverman, and Hemali Thakkar who I worked with on the early development of that technology as a clean energy generator for lighting.

For the field study, I’d like to thank Viola Nyakato (MUST), Wendo Olema (MUST), Nicholas Mwine (MUST), Judith Iradukunda (MUST), Nicholas Masson (UC Boulder), Ricardo Piedrahita (UC Boulder), Samuel Killewo (Harvard), Jon Rea (MIT), David Bangsberg (MGH), and Jessica Haberer (MGH).

For the biological MFC experiments I’d like to thank Ang Cui (UToronto), Elena Stamenova (Broad Institute), Zoe Xiao (RPI), Maxim Massenkoff (Harvard), Julia Zakorski (MIT), Jose Gomez-Marquez & the MIT D-Lab (MIT), and Jason Hana & Greentown Labs.

For their work on the design and manufacture I’d like to thank Jordan Stephens (Harvard), Andrew Jean-Louis (Navigant), Jay Zignego (Zigco), Fred Huettig (StarBoard Design), and Betsy Soukup (MIT).

My five years at Harvard Medical School often felt like a tightrope-juggling act between maintaining my medical studies, research, and family, and I benefitted tremendously from the support of a number of people at HMS. In particular I’d like to thank Dr. Ron Arky, Dr. Beverly Woo, Dr. Bruce Walker, Dr. David Hirsh, and Cathy Holcomb, as well as my wonderful panel of mentors at Cambridge Hospital for my PCE for their support and understanding throughout this time.

Finally - my family. It’s been 5 years of both great and terrible things. Thanks for everything.



## ACRONYMS/ABBREVIATIONS

bp	base pairs
CDC	Center for Disease Control
EC	elemental carbon
HMS	Harvard Medical School
MFC	microbial fuel cell
MUST	Mbarara University of Science and Technology
OC	organic carbon
OCV	open circuit voltage
UNCST	Ugandan National Council of Science and Technology
WHO	World Health Organization

## TABLE OF CONTENTS

<b>Abstract</b> .....	<b>ii</b>
<b>Dedication</b> .....	<b>iii</b>
<b>Acknowledgements</b> .....	<b>iv</b>
<b>Table of Contents</b> .....	<b>v</b>
<b>Abbreviations</b> .....	<b>vi</b>
<b>Chapter 1 Overview</b> .....	<b>1</b>
<b>Chapter 2 Clean Energy and Respiratory Health in Rural Uganda</b> .....	<b>6</b>
<b>Abstract</b> .....	<b>6</b>
<b>Introduction</b> .....	<b>6</b>
<b>Methods</b> .....	<b>10</b>
Household Selection.....	10
Air Quality Measurements.....	11
Symptom Assessment .....	12
<b>Results</b> .....	<b>13</b>
Air Quality .....	16
Symptomatology.....	18
<b>Discussion &amp; Conclusions</b> .....	<b>20</b>
<b>Chapter 3 Microbial Fuel Cells: Bug Optimization</b> .....	<b>23</b>
<b>Abstract</b> .....	<b>23</b>
<b>Introduction</b> .....	<b>23</b>
<b>Methods</b> .....	<b>26</b>
Inoculate and Feed.....	26
Microbial Communities .....	28
<b>Results</b> .....	<b>29</b>
<b>Discussion</b> .....	<b>37</b>
<b>Chapter 4 Microbial Fuel Cells: Hardware Optimization</b> .....	<b>39</b>
<b>Abstract</b> .....	<b>39</b>
<b>Introduction</b> .....	<b>39</b>
<b>Methods</b> .....	<b>41</b>
<b>Results</b> .....	<b>45</b>
<b>Discussion</b> .....	<b>48</b>
<b>Conclusions &amp; Future Work</b> .....	<b>49</b>
<b>References</b> .....	<b>52</b>
<b>Appendices</b> .....	<b>56</b>
<b>A2-1: Household Interview Guide</b> .....	<b>56</b>
<b>A2-2: Household Interview Guide – Runyankole Translation</b> .....	<b>62</b>
<b>A3-1: Most Frequent Microbes Found in Electrode Communities</b> .....	<b>68</b>
<b>A3-2: Fractions Unassignable Bacterial Sequences By Electrode</b> .....	<b>72</b>
<b>A4-1: Detailed illustrations of modular MFCs</b> .....	<b>73</b>

## Chapter 1 Overview

Respiratory diseases kill more children worldwide than any other class of illness. The WHO estimates that respiratory diseases attributable to indoor air pollution prematurely end more than 2 million lives per year. These numbers include over 50% of pediatric pneumonia deaths. These deaths are disproportionately distributed, with foci in communities with limited access to resources such as proper nutrition, clean water, health care, and clean energy.

Among other factors, air pollution contributes to the frequency and severity of these diseases. As many in developing regions do not have access to clean energy sources, the burning of coal, biomaterials, and petroleum-based fuels such as kerosene for their energy needs. These all produce smoke in and around the home and exacerbate indoor air pollution.

Though there is a consensus in the literature that air pollution damages respiratory health (as well as the health of other systems), it is not clear what interventions in this space would have the most benefit. The primary sources of exposure are not well established. To date, the primary focus of study in developing nations has been the effects of cooking smoke on indoor air pollution and health. A major study in this arena, run by the CDC, WHO, and faculty at multiple international universities, evaluated the health impact of cookstove smoke on young children in the Highlands of Guatemala. They did this via an interventional study that distributed cleaner-burning cookstoves. Intervention households received more modern cookstoves that were less polluting than the traditional cooking

devices. A control group continued to use the traditional cookstoves. The researchers compared the respiratory health (as well as other secondary clinical endpoints such as prematurity and low birth weight) and air quality (specifically CO measurements) in the intervention and control households, and showed the respiratory health of the intervention group showed modest improvement at the end of 18 months [Smith 2011].

It seems clear that cooking smoke is a contributor to indoor air pollution and hence respiratory health. I suspected that another contributor to the indoor air pollution problem was indoor lighting. More than 60% of whole countries' populations, and nearing 100% of some of the rural populations in sub-Saharan Africa and other parts of the developing world light their homes by burning kerosene [Lam 2012]. Kerosene burning is known to produce a number of different pollutants including those associated with respiratory illness [Apple 2010].

Chapter 2 of this thesis describes an interventional field study on clean lighting we conducted in rural Uganda. Households in rural Uganda use primarily kerosene burning lamps as a source of indoor lighting. I probed whether burning kerosene for lighting is a significant contributor to an individual's smoke exposure. I also looked to see if utilizing clean lighting options offers health benefits to users, and whether eliminating kerosene-based lighting has an impact on objective levels of indoor air pollution. Fifty households (25 intervention households who received a solar light to replace their kerosene lamp, and 25 control households who continued to burn kerosene for lighting) and 230 people (123 in the intervention group and 107 in the control group) were included in the study. My results suggest that smoke from kerosene lighting is a major player in respiratory health

and a driver of indoor air pollution. I propose that developing and distributing clean energy technologies to support lighting applications are effective ways of improving health.

Though multiple clean lighting technologies exist, most have not enjoyed the kind of success hoped for by their proponents. There are many issues that may contribute to the relatively limited use of some of these devices, including local availability, ease of use, and startup costs.

In Chapters 3 and 4, I describe my efforts in the development of a novel clean energy technology – microbial fuel cells (MFCs). MFCs are devices that scavenge energy generated from the natural metabolism of certain microbes, many of which are native in soil. Though the scientific community has been aware of the biological phenomenon for over a century, the relatively small amounts of power have limited its applications.

My goal was to further develop the MFC technology, increasing energy output and improve designs to make it an effective source of clean energy for lighting applications in off-the-grid rural regions of the world. Chapter 3 describes the optimization of naturally occurring soil microbes for power production in dirt-inoculated MFCs. I identified several agricultural waste materials to use as “feeds” for the microbial life in the cell. Several, including blood meal, were particularly effective at facilitating growth of microbes that produced 1-2 orders of magnitude more power than our initial MFCs that were fed only with the nutrients native in the soil. I further describe the whole genome sequencing experiments we completed to assess the microbial populations present at the MFC electrodes. I note that



MFCs with a predominance of *Pseudomonas* species at their anodes tend to produce more harvestable energy than those electrodes with other dominant species.

I further wished to address some of the technical issues affecting utilization of MFC technologies in the clean energy space. Chapter 4 of this thesis describes my work in developing the MFC hardware to make it a more effective clean energy power source appropriate for rural, off-the-grid households. I identified substitute components and materials in the construction of the MFCs, specifically replacing the polymer proton exchange membrane with ground silica/sand which is vastly cheaper and more accessible than the polymer. I also designed and produced a modular, easy-to-construct MFC that can be constructed from locally available materials. They are easily connected in parallel and there is no limit to the number than can be easily connected in this fashion. This development process encompassed multiple prototyping, fabrication, and production technologies, in order to create a product that is manufacturable in large quantities.

Finally, utilizing the advances in the technology and design, I created a dirt-powered phone charger. I built 100 of the modular MFCs, using a soil inoculate and a blood meal feed. I connected these 100 cells in parallel and was able to charge a Nokia 1100 phone battery (the Nokia 1100 was the world's most best-selling phone handset in history, and was especially popular in the developing world as it provided basic services and was particularly durable).

In the concluding section, I discuss the potential for further work in the clean lighting and respiratory health space, as well the potential applications and benefits of the MFC technology. I discuss briefly the phone-charging application, as it too is an energy challenge for many who are off-the-grid. The health impact is yet to be explored, but cell phones are being increasingly used as a tool in health care, and a good off-the-grid charging solution has the potential for significant health impact as well.

## **Chapter 2 Clean Energy and Respiratory Health in Rural Uganda**

### **Abstract**

Smoke exposure is known to be a major cause of respiratory illness in the developing world. To date, cookstoves have been the most widely studied source of smoke exposure. We surveyed 50 rural Ugandan households containing 230 people, and found that the average person was exposed to 3.3 hours of smoke from indoor lighting sources, as compared to 42 minutes of exposure from cookstoves. Next, we performed a field trial to assess the impact of clean lighting on indoor air pollution and respiratory health. We provided a solar-powered lantern to 25 intervention households (containing 123 people), and compared them to 25 control households (containing 107 people) who continued to use kerosene lamps. We monitored indoor air quality in intervention and control households over a 3-month period. We found that levels of soot (elemental carbon) in intervention homes were 17-fold lower than soot levels in control homes. After three months, we observed statistically significant reductions in cough ( $p=0.038$ ), sore throat ( $p<0.01$ ), and overall illness ( $p<0.01$ ) in the intervention homes. These findings demonstrate that the introduction of clean lighting can have a rapid and significant impact on overall health in the developing world.

### **Introduction**

Respiratory infections are the number one killers of children under the age of 5 globally [Williams 2002], and have been so for decades [Denny 1986; Wardlaw 2006]. They are also a significant contributor to morbidity and mortality in other age groups as well [WHO 2008].

Many factors contribute to a person's respiratory health. Though the exact mechanisms are often unknown, various pollutants are known to be associated with higher rates of respiratory disease, including infectious disease such as pneumonia [Saldiva 1994; Barnes 2009; Smith 2011]. Also of note, various inhaled pollutants have also been associated with other health risks, including cardiovascular disease [Pope 2004; Zanobetti 2013], diabetes [Brook 2013], low birthweight and prematurity [Sram 2004], and meningitis [Kim 1996].

The movement to characterize air pollution and its health impacts began in the West in the late 1960's to early 1970's. During this period there were multiple studies evaluating the primary indoor pollutants, which included particulate carbon, sulfates, nitrates, other volatile organic compounds, CO, and CO<sub>2</sub> [Samet 1987]. There were also multiple studies over the course of those decades linking air pollution (including specific pollutants [e.g. Pope 1991]) to specific health metrics. These metrics were primarily respiratory health effects, but also evaluated rates of various types of cancers, all-cause infant mortality, and others. The majority of these early studies focused on communities in industrialized nations, such as the US, England, Ireland, and Japan [Lave 1970]. They included studies on the health effects of pollutants from tobacco smoking, NO<sub>x</sub> pollutants from gas stove use, and some data on woodsmoke. There were some limited studies from developing nations, such as Papua New Guinea and South Africa that associated heavy exposure to woodsmoke with acute respiratory illness [Anderson 1978; Kossove 1982].

Starting in the 1990's there has been an increasing focus on air pollution as a major health concern in developing countries as well. Much of the air pollution in developing nations, in

particular the indoor air pollution, stems from direct burning of petroleum and biomass-sourced fuels for household energy needs. Over half the world population, primarily in developing nations of Africa, Asia, and South & Central America burn these fuels for cooking, heating, and lighting [Parikka 2004].

There have been a several studies indicating the associations between various health metrics and air pollution. However, there is limited data available assessing the impact of specific interventions addressing the sources of such pollution. To date, the studies that have been implemented have focused on the impact of burning biomass and coal fuels in cooking [Colfer 2008; Smith 2011].

The most extensive study run to date was focused on cleaner cookstoves in the western Highlands of Guatemala. It was run by the CDC, the WHO, and faculty at multiple international universities, and evaluated the impact of cookstove smoke on 518 young children in the Highlands of Guatemala. They performed an interventional trial in which the intervention group received a cleaner cookstove that was less polluting than the traditional cooking devices. A control group continued to use the traditional cookstoves. The respiratory health of the intervention group showed modest improvement at the end of 18 months [Smith 2011].

It seems clear that cooking smoke is a contributor to indoor air pollution and hence respiratory health. Interventions in this space have been taken up as a movement; clean cookstove interventions are the inspiration for international conferences, celebrity endorsements, and development funding opportunities.

I suspected that another contributor to the indoor air pollution problem was indoor lighting. I reasoned that cooking is primarily done by the lady of the house. While she might keep a very young child with her during her hours cooking, relatively few members of a household would be heavily exposed to this smoke. However, large majorities of off-the-grid populations in sub-Saharan Africa and other parts of the developing world depend on burning kerosene for indoor lighting. Most members of the household would be expected to utilize lighting. Children might utilize it to socialize or study; adults might use it to socialize, read, or work (based on our early site visits). Furthermore, while smoke exposure from cooking typically occurs outdoors or at least in better-ventilated areas outside of the primary family dwelling space, kerosene lighting is used in the frequently enclosed primary home or business.

Given this reasoning, we performed a field trial in rural Uganda to assess the potential impact of clean lighting on respiratory health. Our field trial included fifty households, containing 230 people. Health and smoke exposure surveys were completed at the outset. Half the households received smokeless lights (intervention group) and half were asked to continue utilizing their traditional lighting methods (control group). After three months, health surveys were again administered to both groups. In addition to the survey data we also obtained data on particulate and other forms ( $\text{NO}_x$ 's,  $\text{CO}_2$ , CO, VOCs) of pollution in both intervention and control households. We showed that across the population we surveyed there were nearly five times as many hours of smoke exposure from lighting as compared to cooking prior to our intervention. We found that there was a significant reduction in multiple markers of illness in the group using clean lighting as opposed to the

control group who used kerosene lamps. There was also a marked reduction in the indoor air pollution in intervention households vs. control households.

## Methods

### Household Selection

We obtained IRB approval for our study from Harvard University, and the Mbarara University of Science and Technology (MUST). We also obtained approval for our study from the Ugandan National Council for Science and Technology (UNCST). Harvard Medical School ceded review to Harvard University.

We identified two parishes in the Mbarara region of Uganda. We introduced the study to the community at community meetings and obtained the permission of the community leaders to administer the study. A screening survey was completed. Households where members described access to the electricity via the electrical grid or solar panels were to be excluded from the study (no household among those chosen reported such access).



**Figure 2-1. Research assistant conducts a lottery at one of the community meetings.**

Fifty households represented at meetings were selected by lottery to participate; half lotteried into the control group and half into the intervention group. Households in the intervention group received a solar light (d.light S10 solar lantern), and were asked to use these instead of their kerosene lamps during the study period.



**Figure 2-2. Solar light provided to intervention households.** Control households received a solar light at the completion of the study.

Kerosene lamps were not removed from the study households. Households in the control group were asked to continue utilizing their normal sources of indoor lighting, and would receive a solar light at the end of the study. A field worker visited each household every 7-10 days.

### **Air Quality Measurements**

We collected data on 2.5  $\mu\text{m}$  particles. Particulate matter was collected using Pall Corp. 25 mm quartz filters with URG filter samplers and 2.5  $\mu\text{m}$  cyclones. Four filter samplers were rotated among dwellings in both the intervention and the control groups. The filter samplers were placed approximately 1.7m from the ground in each dwelling.



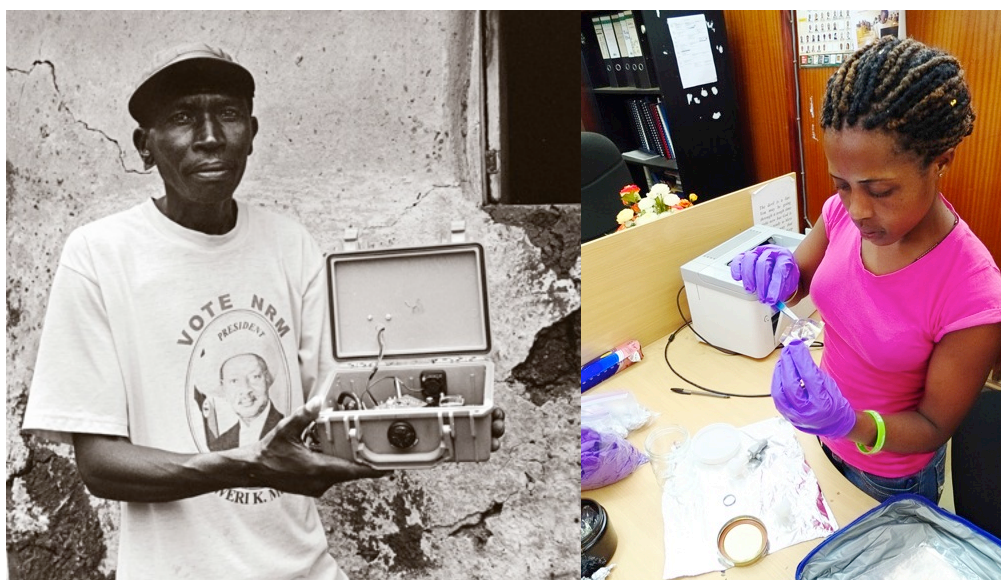

**Figure 2-3. Research assistants in Uganda prepare the sensor equipment for deployment in study homes.**

Filter samplers for ambient measurements were placed at a similar height outdoors in the village. Filters were collected approximately every 3 days. Filters were returned to the US and analyzed for elemental and organic carbon (EC & OC, respectively) using a Sunset Labs OCEC Analyzer and the NIOSH 870 protocol.

### **Symptom Assessment**

At the outset of the study, each member of the fifty selected households were asked to complete a survey. For those too young to complete the survey themselves, an adult member of their household completed the survey on their behalf. The survey was composed in English, translated into Runyankole, and administered verbally in person by a native speaker of the language. Complete versions of the survey in both languages are included in Appendix A2.

The survey evaluated demographic information, current energy usage for cooking and lighting, sources of that energy, and a survey of their current and recent states of health. At

the conclusion of the study, a similar survey was administered in the same fashion. After completion of the study, responses of people who had completed both the entry and exit surveys were included in the analysis. Researchers blinded to intervention and control groups completed analysis of the survey responses.

## Results

In total, 230 people in fifty households completed both the entry and exit surveys. Twenty-five households including 123 people who responded to both surveys were in the intervention group receiving a solar light at the outset. Twenty-five households including 107 people who responded to both surveys were in the control group, which continued to use their normal household lighting.

Typical homes were 3 room enclosures, with a separate building used as a kitchen/cooking facility. Houses typically constituted a living room in which lighting was primarily used, a bedroom, and a storeroom (Figure 2-4). Cooking exposure was limited to the kitchen building, which tended to be less enclosed (e.g. no door, unpaned windows – Figure 2-5).

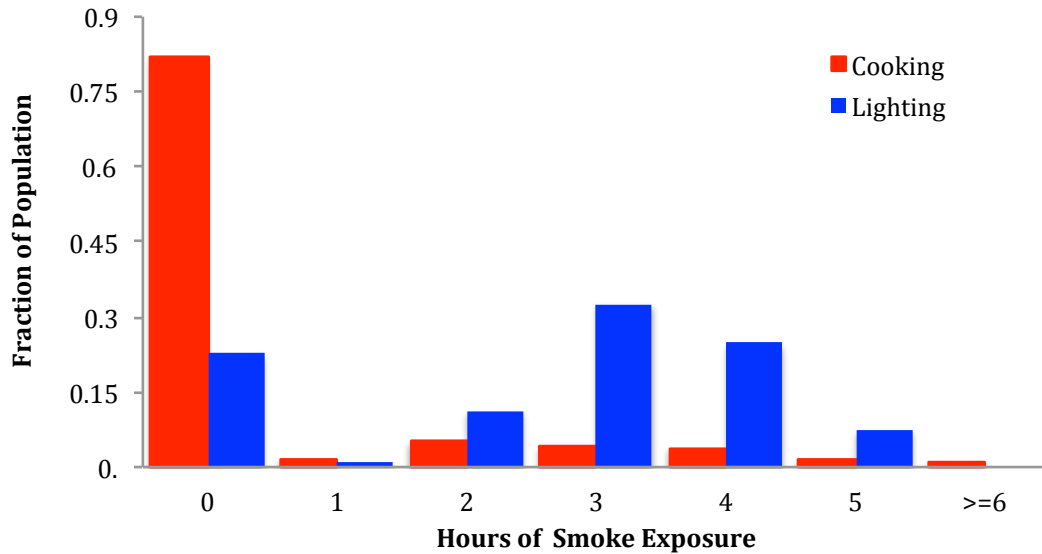

**Figure 2-4. Typical home in our study community in rural Uganda.** Homes typically contained a living room where lighting was used, a bedroom, and a storeroom. Doors and windows were usually closed offering limited ventilation when using kerosene lighting.



**Figure 2-5. Households typically maintain an outbuilding for cooking.** These buildings were more open than the homes themselves. They generally did not have doors or window covers that closed.

The majority of people in the study population report no exposure to cook-smoke, with the majority of people reporting several hours of exposure to smoke from lighting sources (Figure 2-6).



**Figure 2-6. A much larger fraction of the population experiences smoke exposure from lighting as compared to cooking.** In terms of total hours from household smoke exposure, lighting accounts for nearly 5x the amount of cooking time exposure.

100% of households in both groups utilized burning kerosene for most or all of their lighting needs, with approximately 20% of households supplementing with either a battery flashlight or candles. In all cases, these alternate forms of lighting are reported to be used “some/a little bit,” and kerosene listed as the primary source of lighting fuel. Every household used firewood as its primary source of cooking fuel, with 5% using some charcoal as well. Nine adults (9.3% of adults > 18 years old queried) reported themselves as smokers, which is consistent with other studies done in the region [Mondo 2013].



## Air Quality

We evaluated the particulate matter content of eight homes over the course of the study, four homes from the intervention group and four from the control group. Each household was monitored for an average of 12 days over the course of the study.

There was a visible difference in the amount of particulate material collected over 3 days in a control household as compared to a household that received a clean lighting source (Figure 2-7).

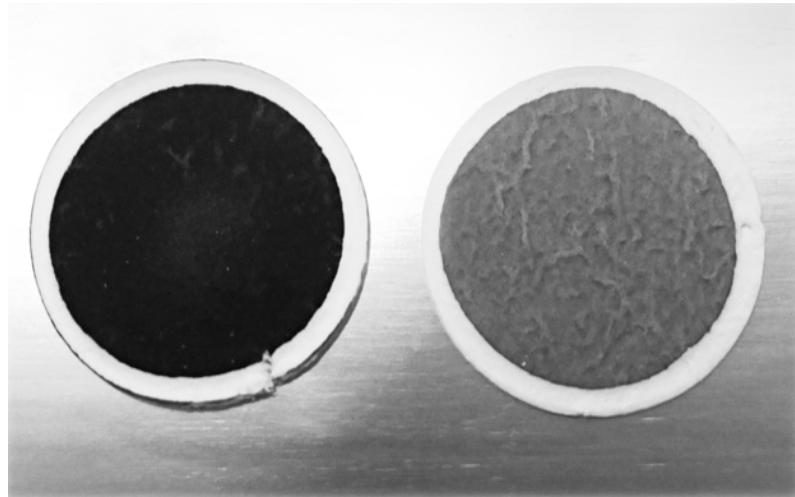

**Figure 2-7. There is a visible difference between particulate materials collected in control vs. intervention household.** Quartz filter following 3 days filtration in a control household (left) and intervention household (right).

Analysis of the particulate matter collected indicated the primary difference between the two groups was in the elemental carbon (EC), or soot content of the indoor particulate matter (Figure 2-8).

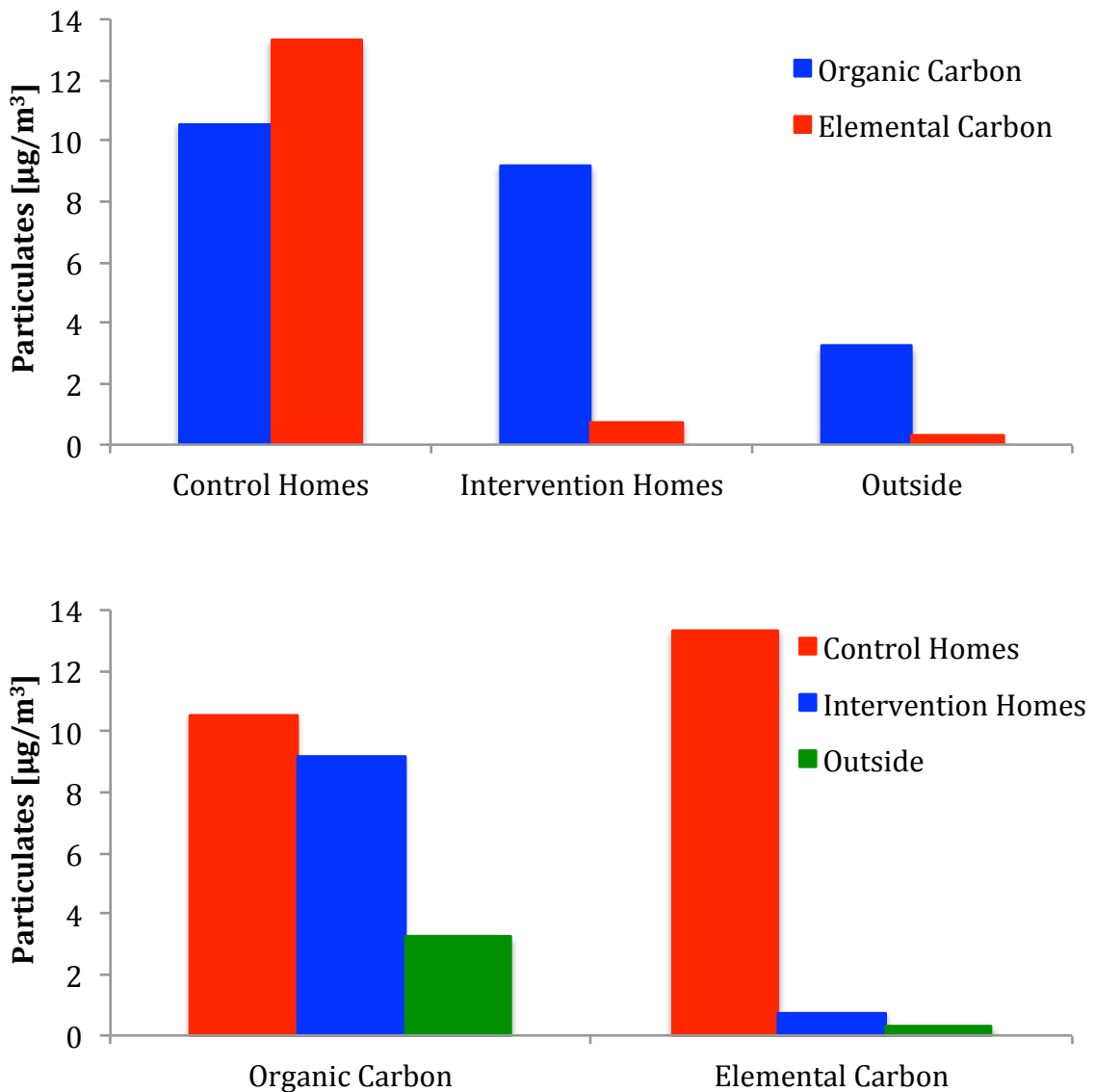

**Figure 2-8. Carbon particulate matter collected in participating households.**

*Upper panel:* Levels of elemental and organic carbon detected on individual filters collected in one intervention and one control household.

*Lower panel:* Average levels of organic and elemental carbon in control households vs. intervention households and ambient conditions. While organic carbon particles remain relatively constant across households at levels higher than outdoor measurements, the amount of elemental carbon particles are markedly reduced in intervention households.

The intervention households were more similar to the ambient outdoor conditions than were the controls in terms of the OC/EC ratio (Table 2-1).

**Table 2-1.** OC/EC values for filters originating in each group of households, as well as ambient conditions.

	<b>OC/EC</b>	<b>stdev OC/EC</b>
<b>Intervention</b>	13.1	6.5
<b>Control</b>	1.9	1.7
<b>Ambient</b>	10.9	1.4

## Symptomatology

People were asked about symptoms over the three months prior to the start of the survey. Several months later at the completion of the survey they were asked about symptoms over the three-month survey period. This we felt would help reduce the amount of bias in reporting (i.e. people were required to report symptoms of the previous three-month period in both cases).

There are several potential sources of bias in this method of surveying. A placebo effect could be present due to participants being informed as to the purpose of the study (i.e. to determine if clean lighting could improve health). Additionally, there could be a bias towards greater consciousness of symptoms due to the Hawthorne effect – the participants may take particular notice of symptoms knowing they will be reporting them at the end of the study. Additionally, because the questions surveyed a roughly six month period, seasonal effects may have contributed to the differences observed, however, given the proximity of the study households, we do not believe this effect disproportionately affected either the control or intervention groups.

Upon entry into the study, there was no statistically significant difference between the two groups of people with respect to their reported symptoms (Table 2-2).

**Table 2-2:** Initially reported symptoms for the 3 months prior to start of study. Includes responses to questions “In the last three months have you been/have you had \_\_\_\_\_?”

	<b>Intervention Group</b>	<b>Control Group</b>	<b>P-value (<math>\chi^2</math>)</b>
<b>Total Number of People</b>	123	107	
<b>Sick</b>	<b>87</b>	<b>84</b>	0.178
<b>Cough</b>	<b>69</b>	<b>49</b>	0.119
<b>Difficulty Breathing</b>	<b>28</b>	<b>30</b>	0.358
<b>Wheezing</b>	<b>22</b>	<b>25</b>	0.304
<b>Sore Throat</b>	<b>25</b>	<b>27</b>	0.375
<b>Red/Itchy/Watery Eyes</b>	<b>60</b>	<b>69</b>	0.017

The chi-squared p-value for reports of red, itchy or watery eyes was  $p = 0.017$ . However when correcting for multiple hypothesis testing using the Bonferroni correction, this value does not meet criteria for statistical significance at 95% confidence ( $1-\alpha_{\text{corr}} = 1-\alpha/m$  where  $m$  is the number of tests and  $\alpha$  is the desired confidence interval). This is a conservative correction, given the variables are likely to be correlated (e.g. someone who is wheezing may also be coughing and ill).

After the completion of the study, we observed there were statistically significant improvements in symptoms in the intervention group as compared to the control (Figure 2-9).



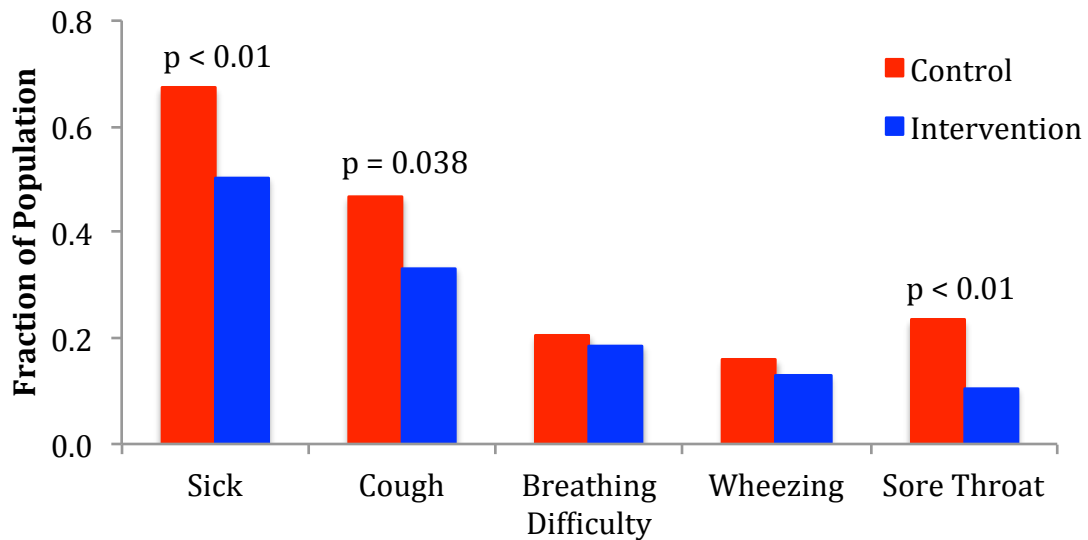

**Figure 2-9. Fraction of each group to report symptoms during the study period.** Overall rate of illness, as well as rate of reporting cough and sore throat were lower in the intervention as compared to the control groups. Reports of breathing difficulty and wheezing were not significantly different.

We attempted to subdivide the groups to evaluate the effects on specific subgroups (e.g. children). Due to sample size, we were limited in our ability to obtain meaningful results, but do note a reduction in the overall rate of illness ( $p < 0.05$ ) in children  $< 18$  years old in the intervention group.

### Discussion & Conclusions

Respiratory diseases lead to nearly 2 million preventable deaths each year in developing nations, where they are the number one cause of death in children under 5. The causal role of stove smoke in health – the so-called “killer in the kitchen” – has begun to be recognized. We showed that the ubiquitous use of kerosene lamps for indoor lighting is likely to also be an important factor.

According to the WHO, nearly 2 million people die prematurely every year due to the burning of fuels inside the home. This number includes nearly three quarters of a million children. Lower respiratory infections account for > 11% of all deaths in low-income countries, and 4-5% of deaths in middle-upper income countries as well. Our study in rural Uganda (per capita GNI of \$1,310, which barely squeaks into the middle-income range) underlined the potential impact of clean lighting options. Our work underscores both the negative impact of dirty vs. clean lighting on objective air pollution measures, as well as on subjective symptoms experienced by members of the household. For instance, we observed a 40% reduction in reported cough symptoms in the intervention group, as compared to a 2% increase in reported cough symptoms in the control group at the end of a 3-month trial.

Kerosene lamps are the primary source of light for over 1.7 billion people worldwide. Our study assessing the impact of clean lighting on respiratory health and air quality in rural Uganda showed that there is broad exposure within the households to air pollution from lighting sources, as compared to the more limited exposure to cookstove smoke. Our analysis suggests that replacing kerosene lanterns with clean lighting can lead to reductions in overall rates of illness, cough, and sore throat among all members of the household – not just those exposed to cooksmoke. This does not assess the relative magnitudes of exposure per unit time, or the relative impact of the various types and durations of exposure on health, both of which warrant additional study.

Assessment of additional markers of impact in both clinical and chemical spheres will cast greater light on the ways in which health can best be improved. We have collected

additional data on various other pollutants that can stem from kerosene burning and it will be useful to see what directions these data lead in terms of future studies. Quantifying the effects in a larger group, as well as over > 12 months to account for seasonal effects will be important components.

Although there are still many questions outstanding as to the magnitude and nuance of the impact of clean lighting on health, it seems clear that lighting is a potentially high impact locus of intervention for improving health in developing parts of the world.

## Chapter 3 Microbial Fuel Cells: Bug Optimization

### Abstract

Soil-based microbial fuel cells (MFCs) harvest electrons produced by microbes in soil to generate electricity. Consequently, unlike solar cells, MFCs can be cheaply and easily built using materials that are available almost anywhere in the world. As such, they have the potential to be a potent source of clean energy for lighting in off-the-grid areas of the developing world.

Maximizing the power output of soil-based MFCs is a central challenge. Here, we examine the efficacy of common agricultural byproducts, available throughout the developing world, at enhancing the power output of soil MFCs. We find that blood meal (dried animal blood) leads to a ten-fold increase in power output. We then use massively parallel DNA sequencing to determine which microbes are most electrogenic. We find a strong positive correlation between power output and the frequency of the genus *Pseudomonas* in the microbe population.

### Introduction

Clean energy and lighting solutions can have a substantial impact on health in parts of the world whose people currently have limited access to such energy sources [Torres-Duque 2008; Wilkinson 2009]. There are many potential sources of energy for clean lighting, including cleaner burning fuels and systems (such as cleaner burning oil in place of kerosene, or cleaner burning stoves), traditional large-scale clean energy options including

nuclear, wind, and water power, as well as solar power and other less commonly utilized options.

Clean energy in the developing world, however, is far from a solved problem. For many communities, traditional sources of clean energy, particularly the large centralized sources, have proved ineffective at providing widespread availability of clean, affordable energy in developing parts of the world [Ahlborg 2011; Kirubi 2009; Madubansi 2006; Sebitosi 2007]. Many larger-scale systems, including traditional coal-burning power plants, nuclear, water, and wind power have prohibitive initial investment requirements. Even smaller centralized facilities, such as village-scale diesel generators or solar arrays have failed to make a big dent in the availability of energy.

Small solar panels and disposable batteries used to power flashlights have had the biggest household level impact on lighting in the (substantial) areas of sub-Saharan Africa that remain off the grid. Yet, as we saw in the course of our Ugandan field study, these two sources account for only a very small fraction of energy utilization for lighting, likely due to a combination of high cost and limited availability. An optimal solution for lighting power would be a source that can be tapped inexpensively, utilizing locally available materials.

A potential, but hitherto underutilized such source of power for clean lighting is energy extracted from naturally occurring microbial communities. Microbial 'electrogenesis' has a great deal of potential as a power source for the developing world. This is because naturally occurring soil microbes can produce free electrons during the course of their ordinary metabolic processes [Lovley 2006]. Thus, by using an appropriate surface to

harvest these electrons, it is possible to produce power in extremely remote settings with a minimum of infrastructure.

This is exactly what a microbial fuel cell (MFC) is designed to do. The microbes in a single cubic meter of soil can produce approximately 10 kW of harvestable power, although extracting a large fraction of this power is difficult in practice. Nevertheless, even a very low efficiency MFC can be useful for a variety of applications [Logan 2008].

Among the barriers to more general use of MFCs are their practical energy output, the price and accessibility of materials currently used in MFCs, and complexity of their construction and use. The power output for any single microbial fuel cell tends to be low under the best of circumstances; on the order of microwatts or milliwatts per square meter of electrode [Liu, Ramnarayanan et al 2004; Logan 2008]. The fuel cells tend to utilize multiple expensive components including electrodes doped with platinum catalyst, and pricey polymer membranes to boost efficiency [Liu, Ramnarayanan, et al 2004]. It is often difficult to procure even far more basic materials in some of the regions that would most benefit from such a technology. And finally, extant MFCs are often cumbersome, and difficult to use together in large numbers. Our goals involved addressing some of these challenges associated with MFC use. Specifically, we focused on a few areas:

(1) Microbial optimization (Chapter 3)

- a. MFC feed materials: we identified feeds for an MFC inoculated with naturally occurring soil microbial communities that would be accessible for an off-the-

grid community. Specifically we focused on the use of agricultural byproducts as feeds.

- b. Microbial communities: we studied the microbial communities at the MFC electrodes using whole genome sequencing technologies, and identified bacterial species (in particular *Pseudomonas*) that are associated with greater energy outputs.

## (2) Hardware Optimization (Chapter 4)

- a. Materials evaluation: we identify appropriate materials to significantly lower the price of MFC construction. We focused on utilization of silica sand as a substitute for the frequently used Nafion proton exchange membrane
- b. Modular manufacturable design: we design and manufacture 500 MFCs utilizing multiple prototyping and fabrication technologies.

## (3) Utilization and testing (Chapter 4 & Conclusion)

- a. Phone charging: Using the manufactured MFCs and an off-the-shelf voltage booster designed for low-power energy scavenging we built a dirt-powered phone charger that effectively charged a Nokia 1100 cell phone battery.
- b. Construction in Uganda: MFCs were constructed for testing in rural Uganda utilizing locally available materials.

## Methods

### Inoculate and Feed

Our experimental system was constructed using a soil-inoculate for the MFCs. The majority of the population in the relevant region of sub-Saharan Africa that was our focus are

farmers, and hence the concept of ‘growing’ resources from soil was one that would be familiar. Though many microbial fuel cells in development today [Lovley, *Curr Opin Biotech* 2006; Rabaey 2003; Ringeisen 2006] utilize a pure culture of microbes (wild type or evolved) that are relatively efficient at producing electricity, the cost in money and energy required to maintain and transport such a culture, combined with the logistical, legal and other issues associated with utilizing such microbes in a device made the naturally occurring soil microbes an appealing choice.

We created five MFC replicates utilizing several different feeds. The feeds, listed in Table 3-1, consist of various types of agricultural waste materials. Also constructed were five replicates of MFCs generated with no feed other than the soil inoculate, and two ‘sterile’ controls constructed with all-autoclaved components.

**Table 3-1** List of materials and sources for products used as feeds

<b>Material</b>	<b>Source</b>	<b>Product ID</b>
Banana peel	Local Grocery	Loose
Blood meal	Amazon.com	ASIN B003UNYG50
Bone meal	Amazon.com	ASIN B001H1ESNG
Cheese rind (goat cheese)	Local Grocery	n/a
Fish bone meal	Amazon.com	ASIN B0047BIVOK
Seaweed powder (kelp)	Amazon.com	ASIN B00064SYSU

MFCs were constructed in 120 mL glass jars (Container and Packaging Supply, item #G050). Anodes and cathodes (circular, 5 cm diameter) were cut from ¼” graphite felt (Morgan AM&T, VDG grade). Electrodes were mechanically wired (i.e. no adhesive) with 22 gauge titanium wire and the remaining wire protruding from the electrode was insulated with PVC heat-shrink tubing (McMaster Carr, item# 7132K322 and 7132K088). Anodes and cathodes were cleaned with 90% ethanol and rinsed with distilled water and allowed



to dry overnight prior to installation. Cell construction within the jar is illustrated in Figure 3-1.

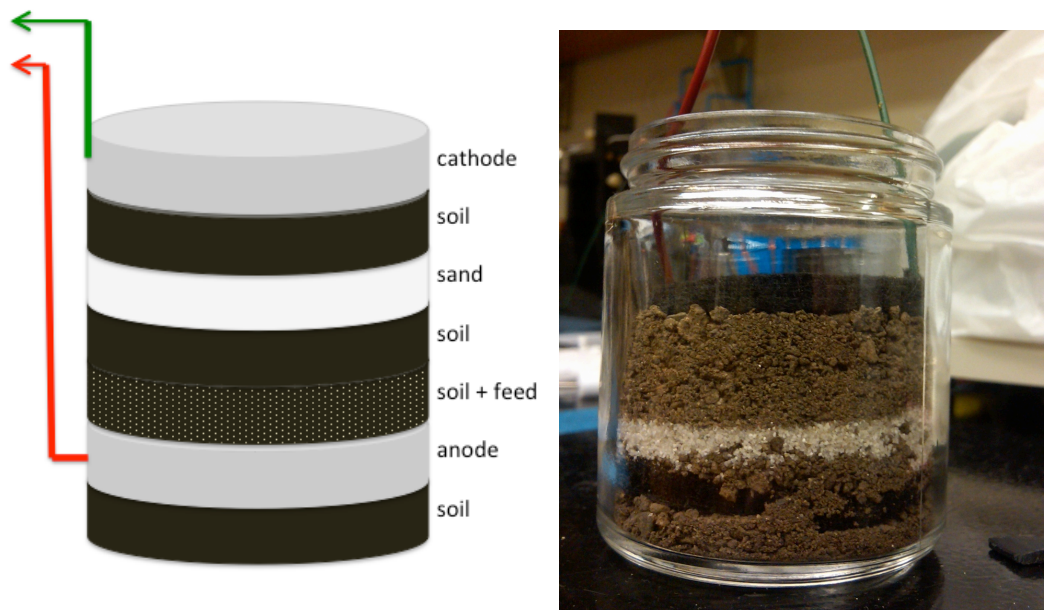

**Figure 3-1. Schematic of layers within the MFC container.**

*Left panel:* Glass jars were utilized to minimize O<sub>2</sub> penetration to the anode compartment. The silica sand was placed to perform a similar function. Feed material was concentrated in the anode compartment to facilitate the growth of electrogenic microbes.

*Right panel:* Image of an MFC under test.

Open-circuit voltage measurements were obtained on the Labjack U12 with three MUX80 and CB37 terminal expansion boards. Data was logged every 10 minutes using the DAQfactory Base software. Power measurements were made applying a 300 ohm resistor across the electrodes and measuring the voltage after 10 minutes.

### Microbial Communities

After 1000-1200 hours of continuous run-time, cells were deconstructed and samples of the anode and cathode felt were obtained for each cell. A subset of these samples was prepared for whole genome sequencing.

DNA was isolated from each sample using PowerSoil DNA isolation kits (MoBio #12888). DNA was sheared to 300-500 base pair segments via sonication using a Covaris LE220. Sheared DNA ends were repaired and the DNA was purified using a Qiagen MinElute column per the manufacturers instructions. 300-500 bp segments were selected using gel electrophoresis. DNA excised from the gel was purified with a Qiagen gel extraction kit. DNA concentration was determined using the Qubit fluorometer. Indexing adapters for each sample were ligated and amplified using 6 cycles of PCR and concentration of the purified amplified DNA was quantified on the Qubit fluorometer. The samples were prepared for MiSeq sequencing with a MiSeq Reagent Kit per the manufacturer's instructions. Sequencing of samples was performed on a MiSeq sequencer with 94% of reads passing internal quality filters. Sequences were annotated using the MG-RAST analysis platform.

## **Results**

We collected between 1000 and 1200 hours of open circuit voltage measurements at 10-minute intervals for 32 cells utilizing six different feed types and two controls. The six feed types were assessed with 5 replicates each. Two sterilized cells were measured as controls. Average OCV at 1000 hours is shown in Figure 3-2, and daily averages across replicates are shown in Figure 3-3.

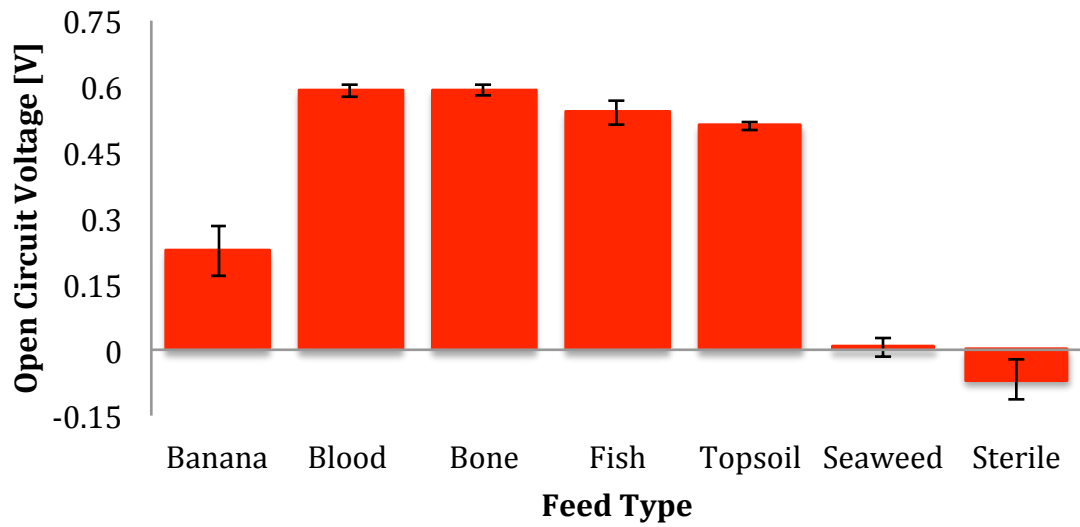

**Figure 3-2. Average OCVs of MFC replicates after 1000 hours of operation.** Five replicates of each feed and 2 sterile cells were generated, and their OCVs were average. Error bars are standard deviations across replicates.

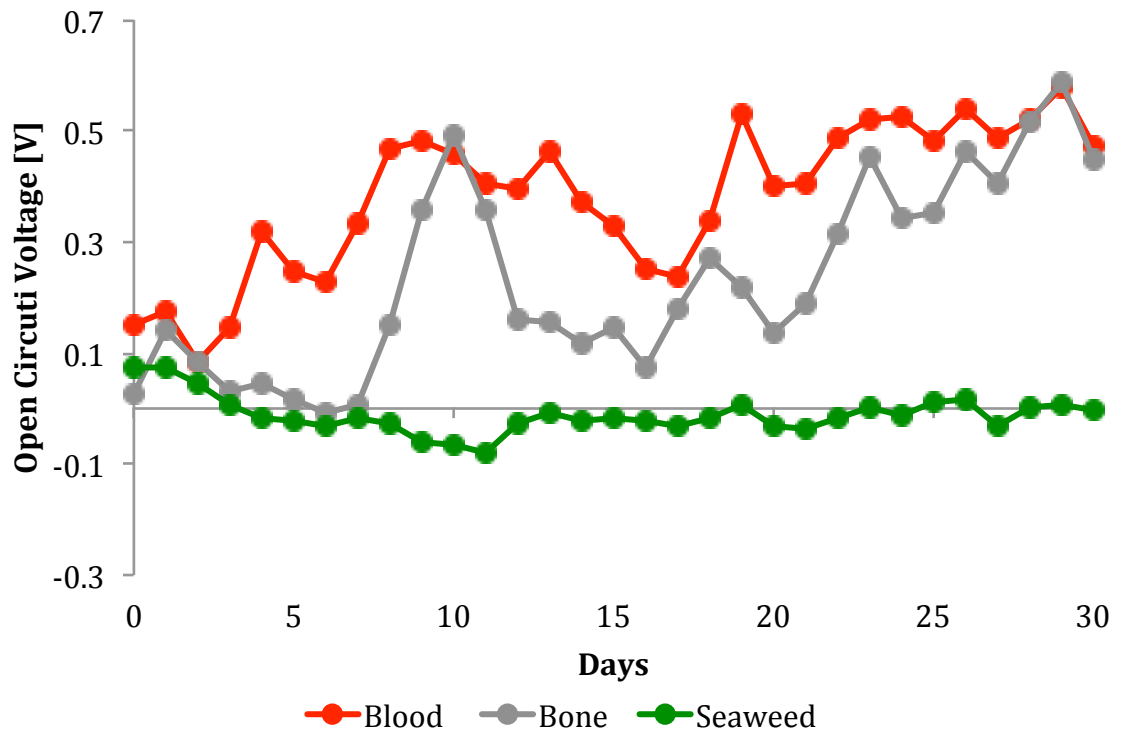

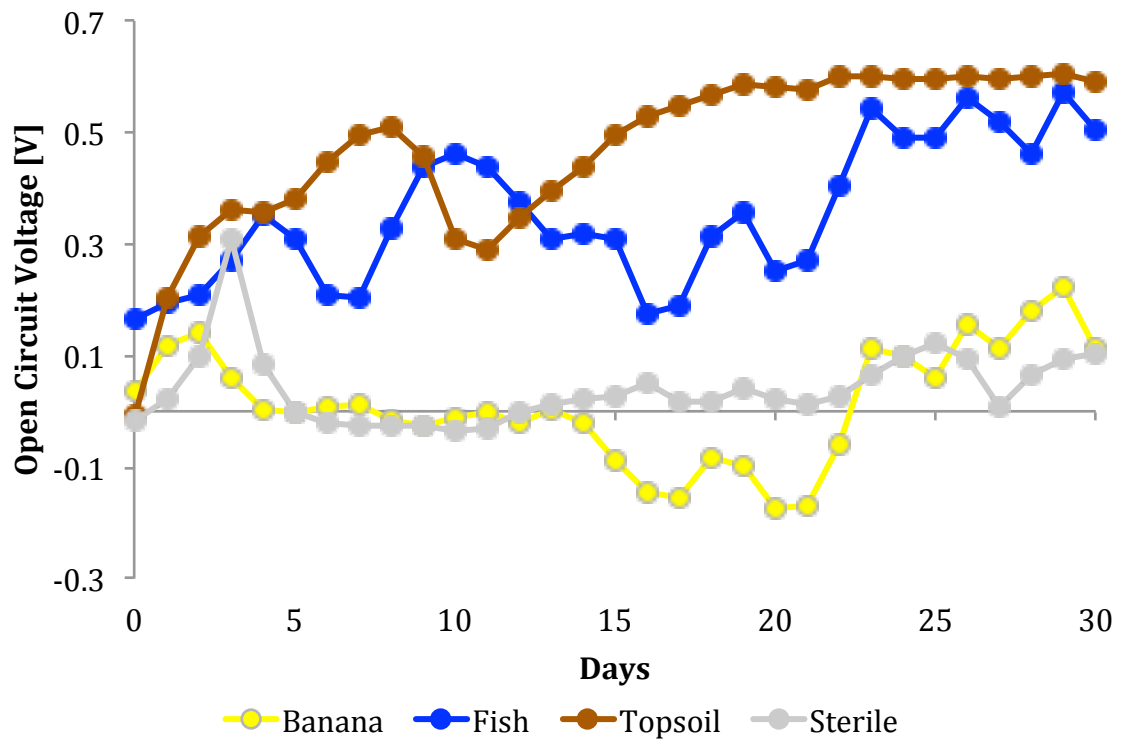

**Figure 3-3: Daily OCV averages of 10-minute interval measurements across 5 replicates per MFC feed type.**

*Upper Panel:* Daily averages of 10-minute-interval measurements for 5 replicates of 3 different feed types.

*Lower Panel:* Daily averages of 10-minute-interval measurements for 5 replicates of 3 different feed types. Daily averages across 10-minute interval measurements of two sterilized control cells are included as well.

After approximately 850 hours, power measurements were made on several cells using a 300 ohm resistor. Though the open circuit voltages were similar, the power output of the cells fed blood meal was in the 300-400  $\mu\text{W}$  range, whereas the power of the bone-meal-fed cells fell in the 80-170  $\mu\text{W}$  range. The seaweed-fed cells did not produce measurable quantities of power. Not unexpectedly, the sterilized cells also did not produce measurable quantities of power.

We performed whole genome sequencing on the DNA extracted from a subset of the electrode samples. The DNA extracted was ~85% bacterial, with small fractions of eukaryotic, archaea, or viral DNA. Approximately 12% of the DNA came from other sources or was unclassified (Figure 3-4).

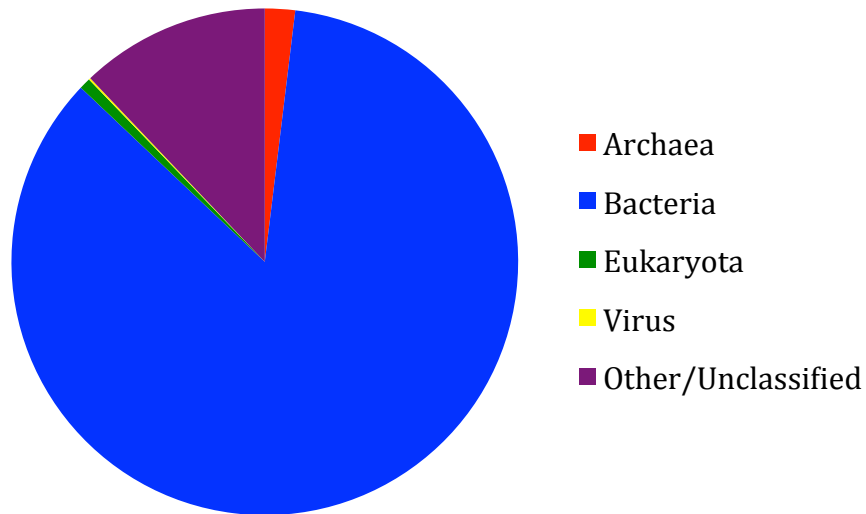
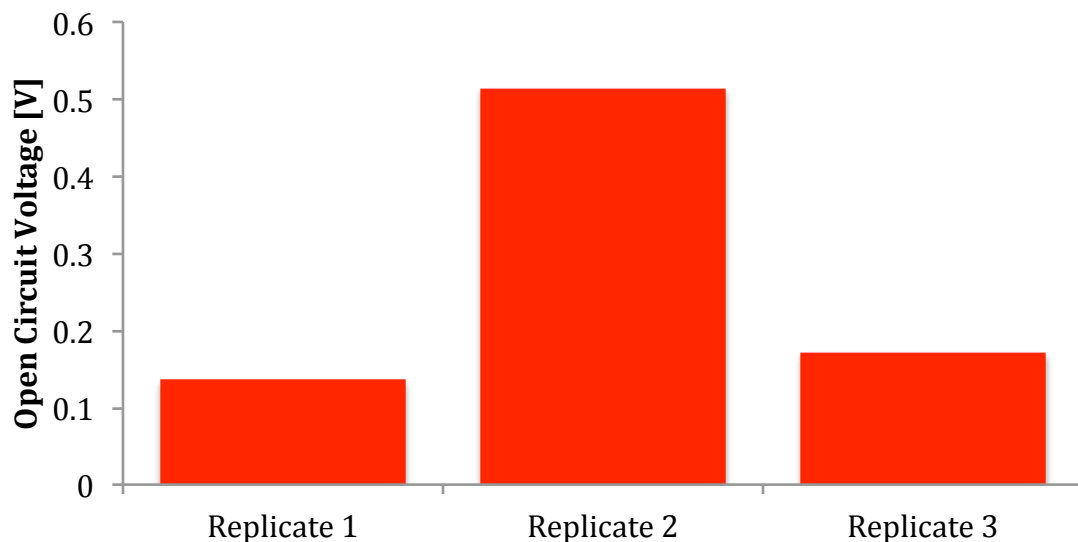

**Figure 3-4. The majority of DNA isolated from MFC electrodes is bacterial in origin.** Small fractions of DNA isolated and sequenced were from other organism classes, or unclassifiable.

On average, 19% of the bacterial sequences were unassigned, either due to the presence of proteins not recognized by MG-RAST, or due to the presence of a sequence sufficiently common so as to make it unassignable to a particular species (Figure A3-2-1).

The most frequent species for each electrode type are listed in Appendix A3-1. There is marked similarity between anodes from MFCs utilizing the same feeds, but with distinctive populations depending on the feed. The frequency distributions however tend to be very similar.

We also experimented with feeding MFCs with rinds of goat cheese, as many in rural sub-Saharan Africa keep goats. We build three MFCs inoculated with topsoil and fed with a slurry of goat cheese rinds and water. Frequent data collection (10 minutes) was maintained between hours 100 and 400 of operation during which time Replicate 2 operated at an average of 0.65 V OCV, and the other two replicates (1 & 3) operated at averages of 0.1 V and 0.07 V OCV, respectively. After this initial period of measurement, the cells were left unmeasured for approximately 4 months. After that time, the cells remained divergent in their outputs and we sequenced their anodes and cathodes as well.

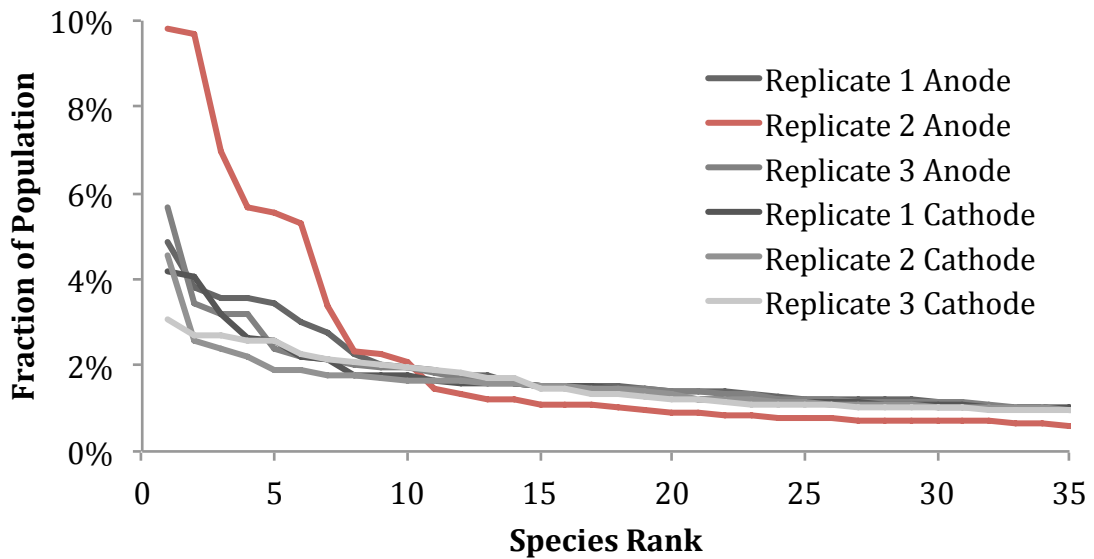

**Figure 3-5. One replicate consistently shows superior performance.** In an experiment with 3 replicates of soil-based MFCs with a feed made from goat cheese slurry, one replicate – Replicate 2 - outperforms the other two over > 4 months of operation.

As can be seen from Figure 3-5, the open circuit voltage of Replicate 2 is consistent higher than the OCV of Replicate 1 and Replicate 3. This was the case after ~100 hours of operation and remained so after a long period undisturbed. Unlike most of the other sets

where the voltage at deconstruction was similar across replicates, this was one set where there was one cell with markedly superior function. This higher-voltage cell outperformed its replicate starting at a very early stage in its life suggesting that the effects stem from either initial or very early population conditions. The inoculate source (topsoil) was consistent across replicates so any differences in initial microbial populations would have been due to the random distribution of microbial species in the soil.

After sequencing samples from each electrode, we compared the populations identified at each electrode. Like the electrodes in the previously described sets of cells, the species frequency distributions within the populations were very similar with one exception (Figure 3-6).



**Figure 3-6. Anode of Replicate 2 (high-voltage anode) has a disproportionate density of its top species.** This suggests these species may be contributing to the improved function of the MFC.

The frequency distribution of species at the anode in the high-power cell was skewed towards an enrichment of the top ~7 species. Other than this electrode, the others

correlated well in terms of their species distribution, with the cathodes correlating somewhat more closely to each other than the low-power anodes. All three cathodes were exposed to very like conditions, exposed on one side to damp soil and on the other, to air, The anodes too, were exposed to environments that were similar across anode compartments, and two of the three anode populations correlated closely together. However the population distribution at the anode of the high-voltage cell was divergent from the populations present at the other two (Figure 3-7).

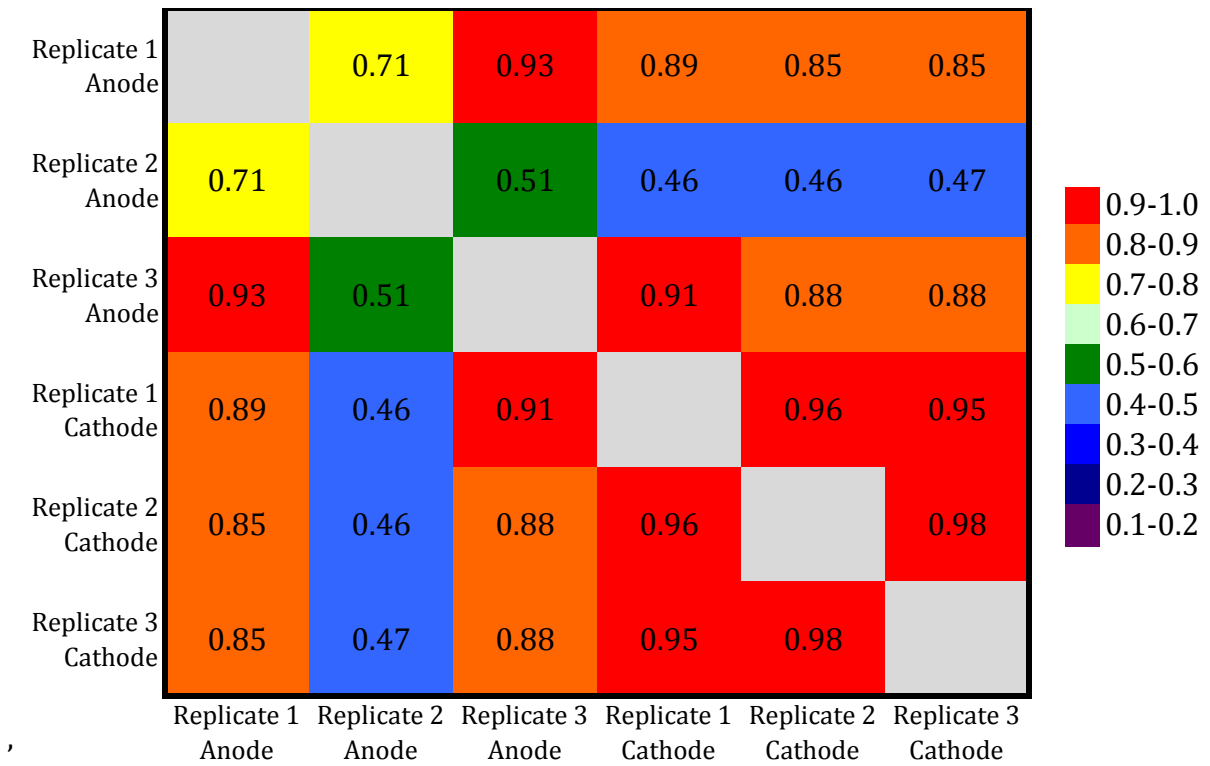
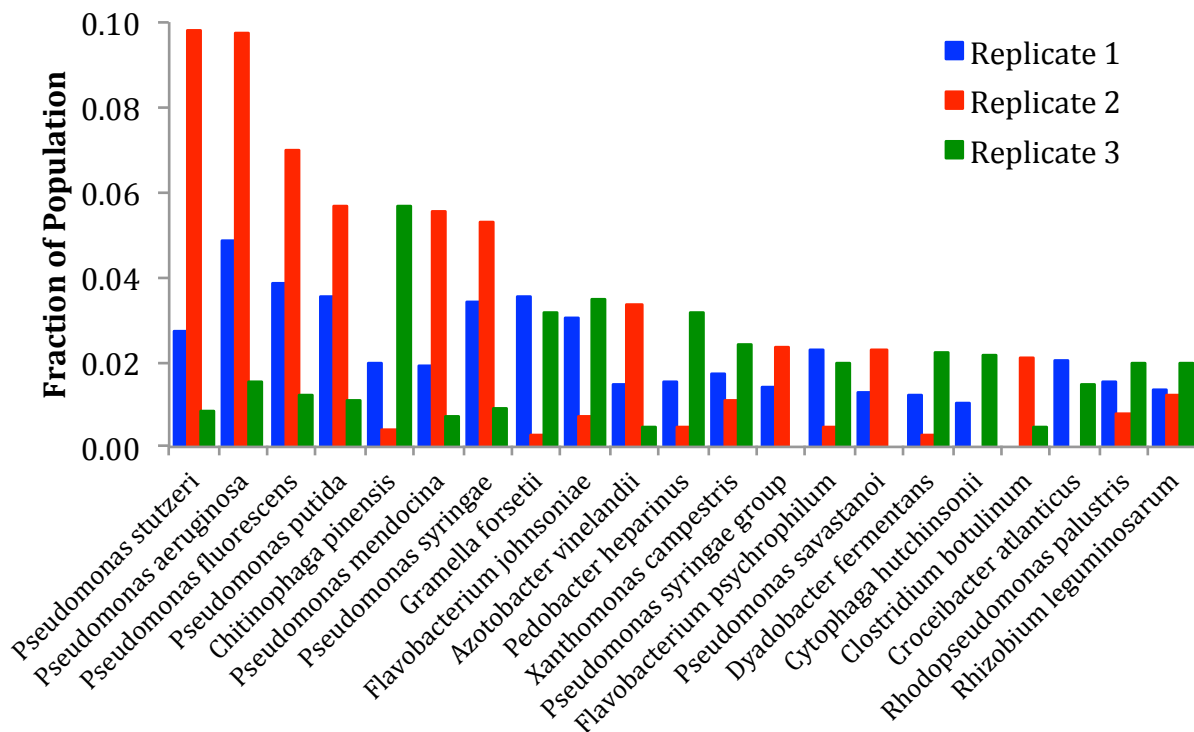

**Figure 3-7. Correlation of species distributions between populations identified at each electrode of three MFCs fed with goat cheese rinds.** Anode of Replicate 2, with higher OCV is most different from communities at other replicate electrodes.

Overall we found representatives of 188 genii at the various electrodes from the rind-fed cells. When considering the top ten species by frequency at each anode, we obtain a total of 21 species, when considering the overlap between electrodes. Of particular note, are the



frequencies of *Pseudomonas* species, in particular at the anode of the high-voltage MFC (Replicate 2).



**Figure 3-8. *Pseudomonas* species are overrepresented in the high-voltage anode relative to any other genus at any other electrode.** *Pseudomonas* is known to produce chemical mediators of extracellular electron transfer and may be facilitating higher voltage MFCs. *Azotobacter vinelandii* is also either a misnamed *Pseudomonas* or a closely related species.

Strikingly, over 50% of the microbes growing at the anode of the high-voltage cell (Replicate 2) were various species of *Pseudomonas* (*Azotobacter vinelandii* is also among the high frequency organisms on this electrode and is debatably a *Pseudomonas* itself [Rediers 2004] (Figure 3-8). This is more than twofold higher than the next most common genus at any anode. Also notable is the presence of a *Clostridium* species, the only Gram

positive bacterium in this set of high frequency microbes at any anode of the cheese-rind-fed MFCs.

## Discussion

A number of agricultural waste materials can be utilized as feeds for the bacteria powering soil-based MFCs. The type of feed has a significant impact on the capacity of the bacteria to produce a voltage across electrodes, as well as the power output of the fuel cell. We observed that cells fed with animal-sourced materials (blood, bone, and fishbone meal) performed better than other sources of feed (banana skin, seaweed). However it remains that effective MFCs can be generated utilizing primarily agricultural waste materials as feeds, making it particularly appropriate for use in agricultural communities with limited access to other sources of power.

Also notable is that the bacterial populations that thrive at each electrode vary significantly by type of feed, as well as the location within the cell. The anode populations tended to be similar across cells utilizing the same feed. The cathode populations varied as much across the cells of varying feed type as among cells within the same feed type, but were still very similar across most cells. This suggests that the anode populations are being driven more by the feed adjacent to the anodes versus the cathode populations that are likely distributions of a stochastic sampling of the microbes extant in the soil. Further characterization of native soil species would be appropriate. Further analysis of anode microbial species' metabolism could potentially correlate to specific feed content and may lend support to this hypothesis.

Our results are also suggestive that the specific bacterial populations that do arise can have a dramatic impact on the output of any individual cell. The MFCs fed with rinds of cheese diverged significantly in terms of their energy output, with one cell overpowering the others by a factor of three. When we examined the populations growing at each electrode, we found that the cathodes were all very similar in terms of their populations and frequency distributions within them, but at the anode of the highly electrogenic cell, we discovered an overabundance of *Pseudomonas* species proliferating there, with over 50% of the bacterial population existing within that genus. This is notable in light of the fact that at least one *Pseudomonas* species is known to excrete pyocyanin [Rabaey 2005] and other redox mediators [Mavrodi 2001] similar to the artificial chemical mediators utilized in some forms of microbial fuel cells. The presence of *Pseudomonas aeruginosa* is also known to facilitate extracellular electron transfer by Gram-positive bacteria [Pham 2008; Rabaey 2004]; of note in light of the *Clostridium* species also present in the top ten anode species (the only Gram positive species to appear on that list). It is also interesting to notice that one of the more recently discovered metal-reducing (and therefore efficiently electrogenic) organisms is also a *Clostridium* species, suggesting another possible role of *Clostridium* species at anodes of MFCs.

## Chapter 4 Microbial Fuel Cells: Hardware Optimization

### Abstract

The typical microbial fuel cell built in an academic or industrial setting contains expensive components (such as a proton exchange membrane) and is cumbersome to construct and operate, particularly in large numbers. Both of these issues limit the utility of MFCs as a viable clean energy option in off-grid areas. Here, we designed and produced a modular, easy-to-construct MFC that can easily be parallelized in order to increase total power output. The resulting device is made of simple materials accessible throughout Africa.

We constructed and operated these cells in rural Uganda. We show that such devices are not limited to powering lights and other very low-power applications. Using 100 of our modular MFCs, deployed in a stacked parallel architecture and fed using blood meal, we were able to charge a cell phone battery.

### Introduction

To date, microbial fuel cells have been used to power small fans and motors, as well as LED lights [Logan 2014; unpublished data from our lab]. These applications have primarily been chosen for their low power requirements, though attempts have been made to incorporate them in useful contexts (e.g. MFC-powered light in a public toilet [Callahan 2014]). Utility of MFCs has been limited by the power output. The power output in turn is intricately interwoven with the significant expense in building traditional MFCs, as well as the challenges associated with using many of them together.

We focused on several aspects of MFC construction. Charging a cell phone battery has an energy requirement several orders of magnitude greater LED lighting, but also constitutes a significant need in many rural communities in sub-Saharan Africa [early site visits, unpublished]. In order to achieve this goal in an affordable way, we needed to adjust the composition of the traditional MFC. Achieving this goal would also likely require the synchronous use of multiple MFCs, thus creating the challenge of creating a modular MFC that could easily be connected to others of the same type. When examining existing designs, we noted several areas where there was opportunity for changes.

Though there are many variants, the typical construction of microbial fuel cells under study in a lab is fairly consistent. They contain two electrodes, anode and cathode, which are usually made of graphite (solid, or some form of graphite fiber, such as fabric, felt, or brushes). Often these electrodes are produced with a heavy metal catalyst, such as platinum [Liu 2004] or cobalt [HouYu 2007]. Occasionally, chemical agents including various dyes are utilized as electron shuttles; these agents are often both pricey and toxic. Finally, a typical fuel cell may also contain a proton exchange membrane between the anode and cathode chambers, which also serves as a barrier to  $O_2$  into the anode compartment [Liu 2004]. These membranes (e.g. Nafion polymer) tend to be one of the most expensive components in the fuel cell. In addition to the limitations based on material pricing and availability, these devices are often cumbersome and difficult to assemble, and are particularly challenging to use together in large numbers.

We took several approaches to addressing some of these. Specifically we focused on eliminating or substituting the proton exchange membrane material, and on developing a modular MFC that can be produced and utilized in large numbers.

## Methods

We opted to utilize graphite felt (a common furnace insulation material) with no catalyst rather than some of the more expensive options on the market. Graphite felt offers substantially more surface area per unit volume than solid graphite, and is in turn significantly less expensive than other graphite options (solid graphite, graphite fabric, or graphite fiber brushes). Since the relevant reactions happen at the electrode surfaces we reasoned this should be a more efficient material. Our earlier work suggested that the felt did not substantially degenerate even with extended use in experiments > 1 year duration, and performed at least as well as the significantly more expensive graphite fabric or solid graphite. We opted against use of metal catalyst given the prohibitive expense and reports in the literature of power outputs not significantly different than our own.

We also assessed whether voltage output of an MFC could be increased utilizing some other material as a barrier between anode and cathode compartments. We chose to assess the efficacy of silica sand as such a barrier. Silica is relatively oxygen impermeable and as such would maintain the anode compartment relatively anaerobic as compared to the cathode compartment.

MFCs were constructed as described in Chapter 3. The layer of silica was placed in one instance just above the layer of feed. In the second instance, it was placed just below the cathode. In the third instance, our control, no silica layer was placed, and no barrier other than the soil itself was utilized. The feed we used for each of these cells was 50 mL of a 200 mM fructose solution (Sigma-Aldrich F3510). Voltage measurements were made using a manual voltmeter every 2-4 days.

To address ease of use issues, we developed a modular molded plastic device with graphite felt electrodes, inexpensive copper alloy tubing, and standard stainless steel fittings (banana plugs) to allow an unlimited number of cells to operate in parallel. Initial designs were prototyped with laser-cut layers of ¼" acrylic completed with stainless steel fittings and graphite felt electrodes described above.

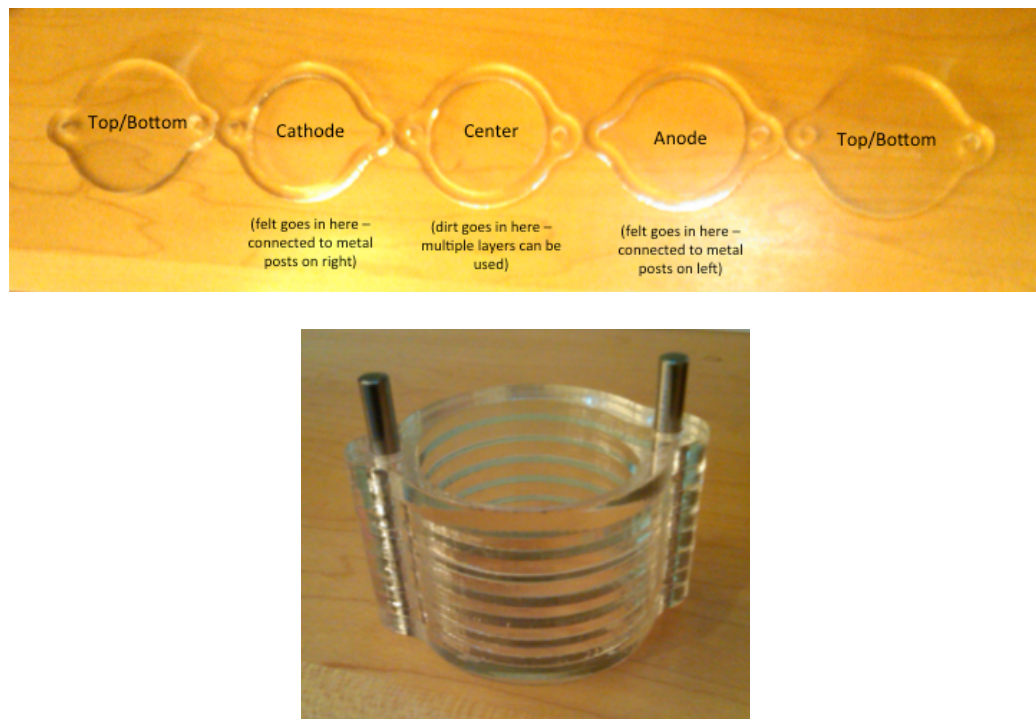

**Figure 4-1. Construction of early designs of a manufacturable MFC.**

*Upper panel:* Components of initial manufacturable MFC design.

*Lower panel:* Constructed stackable cell.

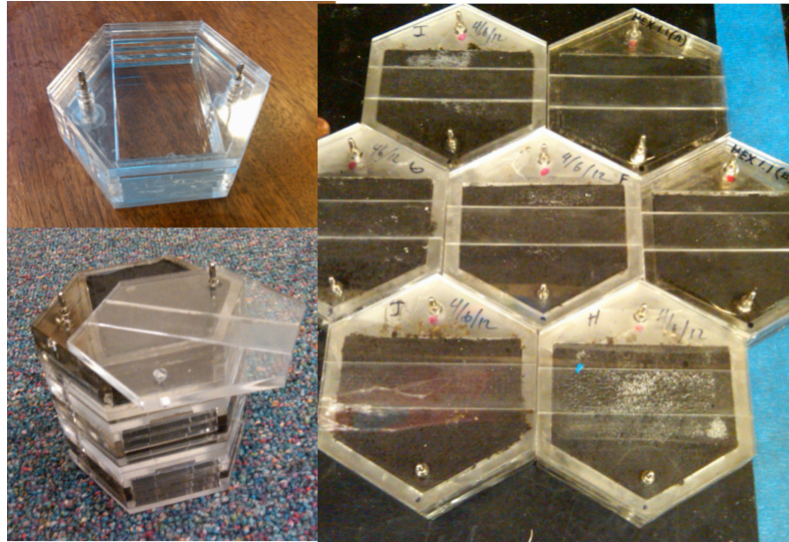

**Figure 4-2. Stackable, packable “hex” version of the laser-cut MFC.**  
*Left panel:* Single empty cell (top) and a stack of 3 constructed cells (bottom).  
*Right panel:* 14 completed cells – stacked and packed.

A prototype of the manufacturable model was 3-D printed and tested prior to construction of a stainless steel mold, and vacuum molding of 500 units. A die was milled to cut electrodes *en masse*. Copper connectors were tapped to allow for insertion of the banana plugs. The manufactured device materials sources are described in Table 4-1, and SolidWorks schematics, as well as images of the molded device are shown in Figure 4-3. A more detailed description and additional images demonstrating the construction of the MFCs are included in Appendix A4-1.

**Table 4-1. Parts and sources for manufactured MFCs comprising the cell phone charger.**

Part	Source	ID
Container/Lid	Protomold	Custom mold
Electrodes	Graphite Insulating Systems	¼" x 4" graphite felt strip
Banana plug (M/F parts)	Mouser Electronics	530-108-0750-1
Copper-110 alloy connectors	McMaster Carr	8966K42
Delrin tube stock (connector insulation)	McMaster Carr	8627K149



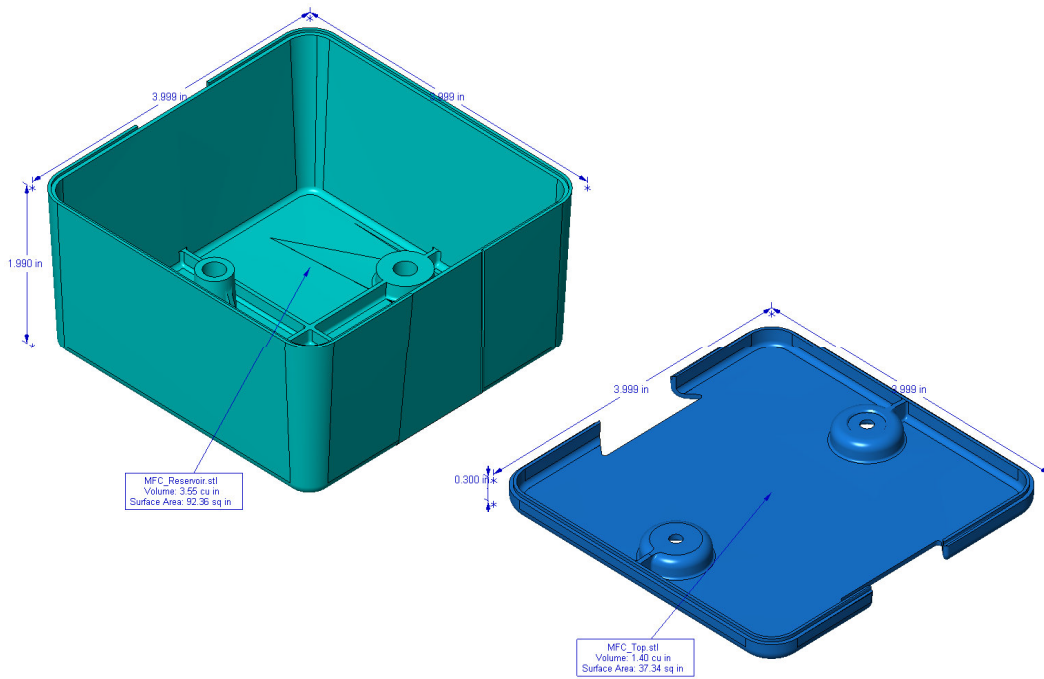

**Figure 4-3. Manufactured MFC designs.**

*Upper panel:* Diagram of moldable MFC with lid. These were initially 3D printed for testing and then vacuum molded in larger numbers.

*Lower panel:* Image of completed components.

We constructed several of these units in the Mbarara region of Uganda using locally available materials.

As noted in the prior chapter, the MFCs under the best of circumstances, have outputs  $< 1$  V, and typically of order 0.5 V. A typical AA battery operates at 1.5 V, and a cell phone battery operates at 3.6 V, so a higher voltage is required to charge it. To increase the voltage to an appropriate level we utilized a voltage booster designed for low-voltage (330 mV) energy harvesting (TI BQ25504).

One hundred cells were constructed using a blood meal feed and connected in parallel. They were utilized to charge a cell phone battery via the voltage booster. The battery charged was a Nokia BL-5C battery and was used in a Nokia 1100 phone.

## Results

Though it does not have the specific proton exchange capacity of Nafion and similar polymers, there was still marked improvement of  $> 5$ -fold in the voltage output of microbial fuel cells utilizing silica as a barrier between the anode and cathode compartments.

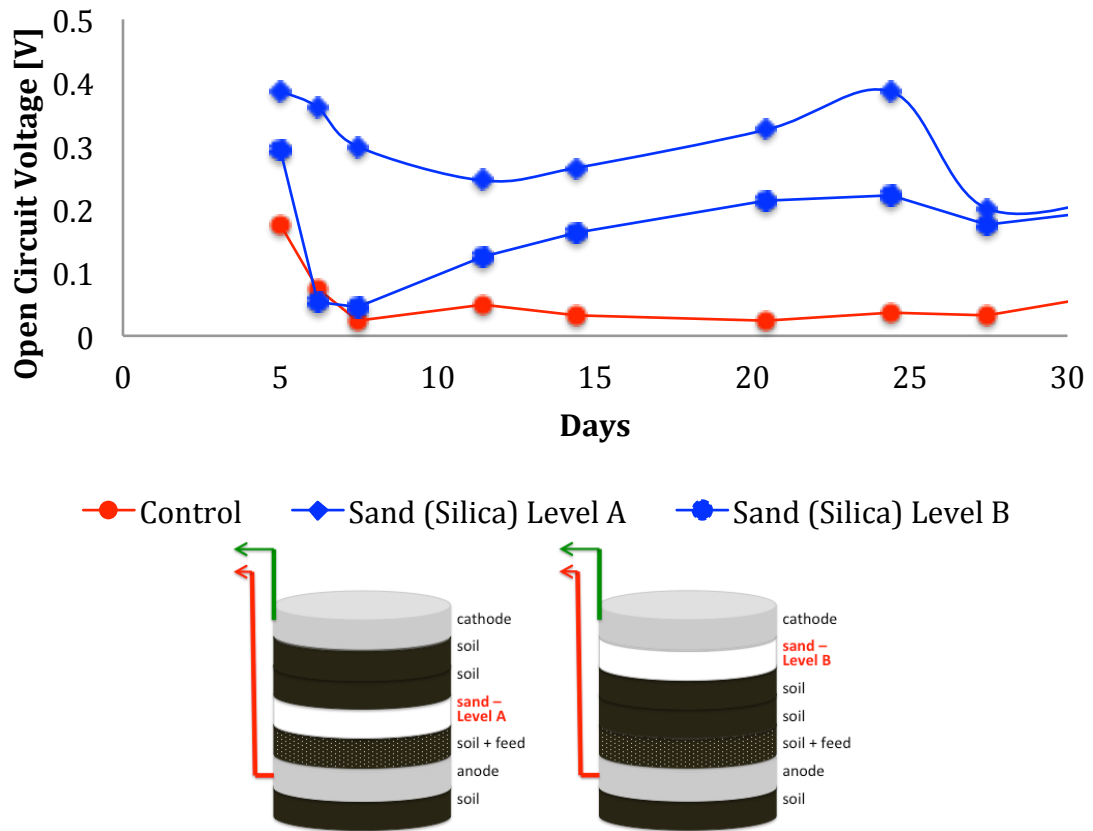
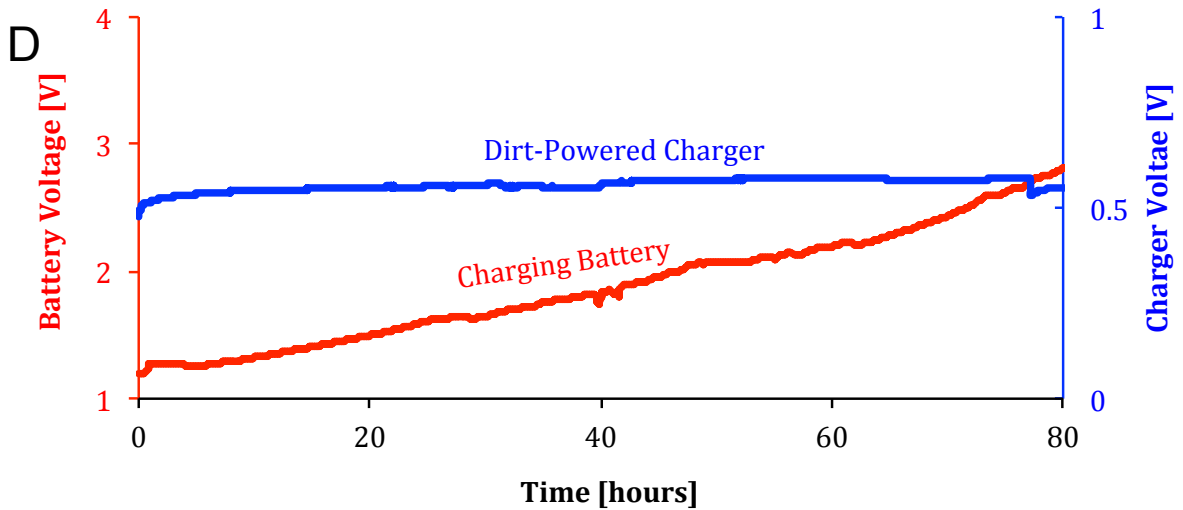
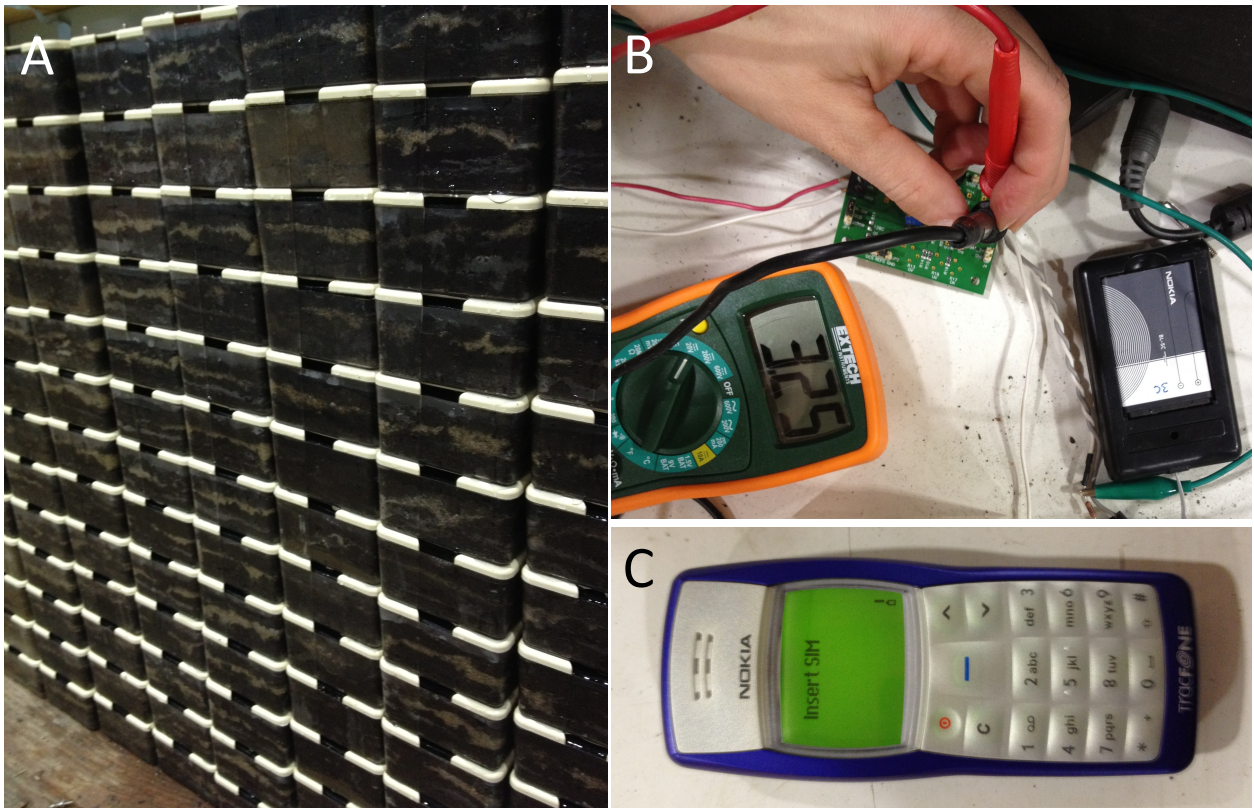

**Figure 4-4. MFCs created with silica separating anode and cathode compartments have > 5-fold improved voltage output after 30 days.**

*Upper panel:* Voltage output for the three cells as a function of days from inoculation.

*Lower panel:* Schematics of the two variants. Control cell was generated with soil in place of a later of sand.

Given these results, and those described in the previous chapter, cells constructed in the phone charger utilized blood meal as feed, and were constructed with a layer of silica at level A. After several days of operation, the system OCV was just above 0.5 V. The battery, starting out with a charge of approximately 1 V, was charged to 3.6 V over 8 days of operation. We were able to then use the battery to power a Nokia 1100 phone (Figure 4-5).



**Figure 4-5. Operational MFC-based phone charger using modular manufacturable components.**

*Panel A:* Dirt-powered microbial fuel cells connected in parallel.

*Panel B:* Cells shown in Panel A charging Nokia 1100 phone battery using commercial voltage booster for low-voltage applications

*Panel C:* Phone powered by dirt-charged cell phone battery.

*Panel D:* Voltage curves of cells and battery during charging.

## Discussion

We found that there are a number of ways to change MFC construction to make them less expensive without significant compromise in power output. This will make them potentially more useful to communities where small amounts of power to charge a cell phone or power a light is helpful. These are communities where many members are living on minimal income and with limited access to complex materials.

We have also developed a relatively inexpensive modular device that can be easily constructed and can be utilized in any number to charge a battery. This design will allow users to spread their startup costs and improve their device as funds permit. We anticipate this design will make the technology more user-friendly to many members of off-the-grid communities with limited financial resources, allowing them to reap the health benefits of clean lighting.

## Conclusions & Future Work

Millions of people die each year because of respiratory infections and other illnesses at least partly attributable to indoor air pollution. Our study showed that smoky lighting is a significant source of exposure to soot and other pollutants, and that clean lighting options to replace kerosene can have a rapid positive impact on health. This study was the first of its kind in the area of clean lighting. Further work including extending the time period of study to encompass at least a full cycle of season would be a valuable addition, as well as including other health metrics. These would include additional metrics in respiratory health, as well as other potentially affected systems.

Assessment of additional markers of impact in both clinical and chemical spheres will cast greater light on the ways in which health can best be improved. We have collected additional data on various other pollutants that can stem from kerosene burning and it will be valuable to identify other elements of indoor air pollution that may affect the health of those exposed. Though there are many outstanding questions, it seems clear that lighting is a potentially high impact locus of intervention for improving health in developing parts of the world.

While there have been great strides forward in the area of clean energy and clean lighting, it is not a solved problem anywhere, and there are particular challenges when working in developing settings. Many people who currently use kerosene and other smoky lighting options have minimal financial resources to cover energy costs, and distribution networks



often limit access to what is available. An inexpensive device that can be locally created and maintained would be the optimal solution.

We worked to develop microbial fuel cell technology as a clean lighting alternative. Utilizing a soil-based system, we identified agricultural byproducts such as blood meal that can feed naturally occurring electrogenic soil microbes and enable them to produce two orders of magnitude more power than we were able to obtain in our very early control experiments.

We were further able to complete metagenomic analyses of the microbial communities growing on our electrodes and showed that highly electrogenic cells had an overabundance of *Pseudomonas* species among the anode populations. This is notable in light of the fact that *Pseudomonas* is known to produce several electron shuttles suspected to enhance the performance of microbial fuel cells. Further exploration of the presence of these shuttles in our system will be useful in enabling us to facilitate the development of highly electrogenic communities, and potentially further enhance this effect.

We were also able to replace a key (and expensive) component of the microbial fuel cell with silica sand as an inexpensive and locally available alternative. We also designed a modular system that can be constructed almost exclusively from locally available materials in Uganda, and was successfully constructed and operated in the rural Mbarara region there. Further improvements to the design, such as the ability to connect horizontally as well as vertically, and in series as well as in parallel would be advantageous. We were able

however to use 100 of these modular cells with a blood meal feed to create a dirt-powered phone charger, which successfully charged a Nokia 1100 cell phone battery.

Phone charging off-the-grid is another challenge faced by many in off-the-grid communities. The health impact is yet to be explored, but cell phones are being increasingly used as a tool in health care, and a good off-the-grid charging solution has the potential for significant health impact as well. Moving MFCs in the direction of a viable phone charger in addition to utilization as a clean lighting source would be a valuable potential application that could also have significant health benefits.



## References

- Ahlborg H, & Hammar L. "Drivers and barriers to rural electrification in Tanzania and Mozambique grid extension, off-grid and renewable energy sources." *World Renewable Energy Congress 2011*. 8-13 May 2011, Linköping, Sweden.
- Anderson HR. "Respiratory abnormalities in Papua New Guinea children: the effects of locality and domestic wood smoke pollution." *International Journal of Epidemiology* (1978). 7:p. 63-72.
- Apple J, Vicente R, Yarberr A, Lohse N, Mills E, Jacobson A, & Poppendieck D. "Characterization of particulate matter size distributions and indoor air concentrations from kerosene and diesel lamps." *Indoor Air* (2010). 20, p 399-411.
- Barnes B, Mathee A, Thomas E, & Bruce N. "Household energy, indoor air pollution, and child respiratory health in South Africa." *Journal of Energy in Southern Africa* (2009). 20(1) p. 4-13.
- Brew-Hammond A, & Kemausuor F. "Energy for all in Africa – to be or not to be?!" *Current Opinions in Environmental Sustainability* (2009). 1 p. 83-88.
- Brook RD, Cakmak S, Turner MC, Brook JR, Crouse DL, Peters PA, van Donkelaar A, Villeneuve PJ, Brion O, Jerrett, M, Martin RV, Rajagopalan S, Goldberg MS, Pope III CA, & Burnett RT. "Long-term fine particulate matter exposure and mortality from diabetes in Canada," *Diabetes Care* (2013). 36(10), p. 3313-3320.
- Callahan PJ. "The Green Latrine." University of Massachusetts, Amherst Research News. <<http://www.umass.edu/researchnext/green-latrine>>. Accessed 01/26/2014.
- Colfer CJP ed. "Chapter 5: Wood, the fuel that warms you thrice." *Human Health and Forests: A Global Overview of Issues, Practice, and Policy*. Earthscan, London, 2008
- Deng Q, Li Xinyang, Zuo J, Ling A, & Logan BE. "Power generation using an activated carbon fiber felt cathode in an upflow microbial fuel cell." *Journal of Power Sources* (2010). 195 p. 1130-1135.
- Denny FW & Loda FA. "Acute respiratory infections are the leading cause of death in children in developing countries." *Am. J. Trop. Med. Hyg.* (1986). 35(10), p1-2
- HouYu E, Cheng S, Scott K, & Logan B. "Microbial fuel cell performance with non-Pt cathode catalysts." *Journal of Power Sources* (2007). 171(2), p. 275-281.
- Kim PE, Musher DM, Glezen WP, Rodriguez-Barradas MC, Nahm WK, & Wright CE. "Association of invasive pneumococcal disease with season, atmospheric conditions, air pollution, and the isolation of respiratory viruses." *Clin. Infect. Dis.* (1996) 22(1) p 100-106.

Kirubi C, Jacobson A, Kammen DM, & Mills A. "Community-based electric micro-grids can contribute to rural development: evidence from Kenya." *World Development* (2009). 37(7), p. 1208-1221.

Kosove D. "Smoke filled rooms and lower respiratory disease in infants." *South African Medical Journal* (1982). 61: p. 622-623.

Lam NL, Smith KR, Gauthier A, & Bates MN. "Kerosene: a review of household uses and their hazards in low- and middle-income countries." *Journal of Toxicology and Environmental Health, Part B: Critical Reviews* (2012). 15(6), p 396-432.

Lave LB & Seskin EP. "Air pollution and human health." *Science* (1970). 169(3947), p. 723-733.

Liu H, Ramnarayanan R, & Logan BE. "Production of electricity during wastewater treatment using a single chamber microbial fuel cell." *Environmental Science and Technology* (2004). 38(7), p. 2281-2285.

Logan BE. *Microbial Fuel Cells*. John Wiley & Sons, Inc. Hoboken, NJ (2008).

Logan BioEnergy Research Group. "Real-time video of a fan powered by a microbial fuel cell." <<http://www.engr.psu.edu/mfccam/>> . Accessed 01/26/2014.

Lovley DR. "Microbial fuel cells: novel microbial physiologies and engineering approaches." *Current Opinion in Biotechnology* (2006). 17(3), p. 327-332.

Lovley DR. "Bug juice" harvesting electricity with microorganisms." *Nature Reviews Microbiology* (2006). 4(7), p 497-508.

Madubansi M, & Shackleton CM. "Changing energy profiles and consumption patterns following electrification in five rural villages, South Africa." *Energy Policy* (2006) 34 p. 4081-4092.

Mavrodi DV, Bonsall RF, Delaney SM, Soule MJ, Phillips G, & Thomashow LS. "Functional analysis of genes for biosynthesis of pyocyanin and phenazine-1-carboxamide from *Pseudomonas aeruginosa* PAO1." *Journal of Bacteriology* (2001). 183(21), p. 6454-6465.

Mondo CK, Otim MA, Akol G, Musoke B, & Orem J. "The prevalence and distribution of non-communicable diseases and their risk factors in Kasese district, Uganda." *Cardiovascular Journal of Africa* (2013). 24(3), p. 52-57.

Parikka M. "Global biomass fuel resources." *Biomass and Bioenergy* (2004). 27(6) p. 613-620.

Pham TH, Boon N, Aelterman P, Clauwaert P, De Schamphelaire L, Vanhaecke L, De Maeyer K, Hofte M, Verstraete W, & Rabaey K. "Metabolites produced by *Pseudomonas* sp. Enable a

Gram-positive bacterium to achieve extracellular electron transfer." *Applied Microbiology and Biotechnology* (2008). 77(5), p. 1119-1129.

Pope III CA, Dockery DW, Spengler JD, & Raizenne ME "Respiratory Health and PM<sub>10</sub> Pollution: A Daily Time Series Analysis", *American Review of Respiratory Disease* (1991). 144(3-1), p. 668-674.

Pope III CA, Burnett RT, Thurston GD, Thun MJ, Calle EE, Krewski D, & Godleski JJ. "Cardiovascular mortality and long-term exposure to particulate air pollution." *Circulation* (2004).

Rabaey K, Boon N, Siciliano SD, Verhaege M, & Verstraete W. "Biofuel cells select for microbial consortia that self-mediate electron transfer." *Applied and Environmental Microbiology* (2004). 70(9), p. 5373-5382.

Rabaey K, Boon N, Hofte M, & Verstraete W. "Microbial phenazine production enhances electron transfer in biofuel cells." *Environmental Science and Technology* (2005). 39(9), p. 3401-3408.

Ringeisen BR, Henderson E, Wu PK, Pietron J, Ray R, Little B, Biffinger JC, & Jones-Meehan JM. "High power density from a miniature microbial fuel cell using *Shewanella oneidensis* DSP10." *Environmental Science & Technology* (2006). 40: p.2629-2634.

Rabaey K, Lissens G, Siciliano SD, & Verstraete W. "A microbial fuel cell capable of converting glucose to electricity at high rate and efficiency." *Biotechnology Letters* (2003). 25: p. 1531-1535.

Rediers H, Vanderleyden J, & De Mot R. "Azotobacter vinelandii: a Pseudomonas in disguise?" *Microbiology* (2004). 150(5), p. 1117-1119.

Saldiva PHN, Lichtenfels AJFC, Paiva PSO, Barone IA, Martins MA, Massad E, Pereira JCR, Xavier VP, Singer JM, & Bohm GM. "Association between air pollution and mortality due to respiratory disease in children in Sao Paulo, Brazil: a preliminary report." *Environmental Research* (1994). 65(2), p218-225.

Samet JM, Marbury MC, & Spengler JD. "Health Effects and Sources of Indoor Air Pollution. Part I", *American Review of Respiratory Disease* (1987). 136(6), p. 1486-1508.

Sebitosi AB, & Pillay P. "Modelling a sustainability yardstick in modern energisation of rural sub-Saharan Africa." *Energy Policy* (2007), 35(1), p 548-552.

Shy CM & Finklea JF. "Air pollution affects community health." *Environmental Science and Technology* (1973). 7(3), p. 204-208.

Smith KR, McCracken JP, Weber MW, Hubbard A, Jenny A, Thompson LM, Balmes J, Diaz A, Arana B & Bruce N. "Effect of reduction in household air pollution on childhood pneumonia

in Guatemala (RESPIRE): a randomized controlled trial." *The Lancet* (2011). 378(9804), p1717-1726.

Sram RJ, Binkova B, Dejmek J, & Bobak M. "Ambient air pollution and pregnancy outcomes: a review of the literature." *Environmental Health Perspectives* (2005). 113(4), p 375-382.

Torres-Duque C, Maldonado D, Pérez-Padilla R, Ezzati M, & Viegi G. "Biomass Fuels and Respiratory Diseases", *Proceedings of the American Thoracic Society* (2008). 5(5) p. 577-590.

Wardlaw TM, Johansson EW, Hodge M, WHO, UNICEF. *Pneumonia: the forgotten killer of children.* (2006) p. 5

Wilkinson P, Smith KR, Davies M, Adair H, Armstrong BG, Barrett M, Bruce N, Haines A, Hamilton I, Oreszczyn T, Ridley I, Tonne C, & Chalabi Z. "Public health benefits of strategies to reduce greenhouse-gas emissions: household energy." *The Lancet* (2009). 374(9705), p 5-11.

Williams BG, Gouws E, Boschi-Pinto C, Bryce J, & Dye C. "Estimates of world-wide distribution of child deaths from acute respiratory infections." *The Lancet Infectious Disease* (2002). 2(1), p25-32.

World Health Organization (WHO). *Global Burden of Disease: 2004 Update* (2008). p. 54

Zanobetti A, Coull BA, Gryparis A, Kloog I, Sparrow D, Vokonas PS, Wright RO, Gold DR, & Schwartz J. "Associations between arrhythmia episodes and temporally and spatially resolved black carbon and particulate matter in elderly patients," *Occup. Environ. Med.* (2013). 0:1-7.

## Appendices

### A2-1: Household Interview Guide

#### Household Entry Interview Guide:

Notes to the interviewer are written in italics.

#### Section 1: Demographics & Household

This section asks about who lives in your household, and what access your household has to electricity

*This section is completed by all study participants*

1. Who is completing the interview?

Name/Initials: \_\_\_\_\_

Address: \_\_\_\_\_

Role in Household: \_\_\_\_\_

2. Who are the members of the household?

Name/Initials	Age	Gender	Relationship to Interviewee	Occupation

3. Does your home have: (circle one)

a. Electricity from the national grid?	Yes	No
b. A generator?	Yes	No
c. Solar panels?	Yes	No
d. Other access to electrical power?	Yes	No

4. If you answered "Yes" to question in 3d please explain below:

*Interviewer: If the household has regular access to a source of electricity, the household is not eligible to participate.*

#### Section II: Potential Smoke Exposures

This section asks about different ways you might be exposed to different types of smoke.

*This section is completed by all study participants*

1. What does your household use for cooking? Circle all that apply

- a. Firewood? I only use this  
I use mostly this  
I use some/a little of this  
I don't use any of this
- b. Charcoal? I only use this  
I use mostly this  
I use some/a little of this  
I don't use any of this
- c. Something else? What? \_\_\_\_\_  
I only use this  
I use mostly this  
I use some/a little of this  
I don't use any of this

- 2. Are your cooking facilities indoors or outdoors (circle)?
  - a. Indoors (separate from living space)
  - b. Indoors (attached to living space)
  - c. Outdoors

3. Who in the household spends time cooking (including only time when the fire is lit)?

Name/Initials	Hours per day spent cooking

4. Who in the household spends time in the same room as the cooking fire while it is lit (including family members who are not cooking such as young children with the mother)?

Name/Initials	Hours per day spent in room with lit fire

5. Does anyone in the household smoke?

Name/Initials	What is smoked (e.g. cigarettes)	How much is smoked per day?	Do they smoke in the house?

**Section III: Cell Phones & Indoor Lighting Use**

This section asks about how you use your cell phone and indoor lighting.

*This section is completed by all study participants*

- 1. Do you have a cell phone in your household? Circle one: Yes No
  - a. If yes, how many phones do you have in the household?
- 2. How much do you use your phones for calls?
  - a. Less than two minutes of call time per day

- b. 2-10 minutes of call time per day
  - c. 10-30 minutes of call time per day
  - d. 30-60 minutes of call time per day
  - e. More than 60 minutes of call time per day
3. How much do you use your phone(s) for sending SMS messages?
- a. Less than once per day
  - b. 1-2 times per day
  - c. 2-5 times per day
  - d. 5-10 times per day
  - e. More than 10 times per day
4. How much do you use your phone(s) for receiving SMS messages?
- a. Less than once per day
  - b. 1-2 times per day
  - c. 2-5 times per day
  - d. 5-10 times per day
  - e. More than 10 times per day
5. What do you use the phone(s) for? Check all that apply
- a. Calling friends
  - b. Calling family
  - c. Business calls
  - d. SMS friends
  - e. SMS family
  - f. Business SMS
  - g. Banking
  - h. Other (specify) \_\_\_\_\_
6. How do you typically charge your phone(s)?
- a. Commercial charging centre
  - b. Friend or neighbor connected to the grid
  - c. Friend or neighbor with a generator
  - d. Solar charger at home
  - e. Other location attached to the grid (specify)
  - f. Other location with a generator (specify)
  - g. Other (specify)\_\_\_\_\_
- 
7. How often do you charge your phone(s)?\_\_\_\_\_
8. If you must pay per charge - how much does it cost to charge your phone?\_\_\_\_\_
9. How long does it take to get your phone charged (including any travel time)?\_\_\_\_\_
10. Have you every used your phone to contact a doctor, midwife, or other medical person?
- a. Yes, by calling
  - b. Yes, by SMS
  - c. No
    - i. If not, why not? \_\_\_\_\_

---

11. What does your household use for indoor lighting? Circle appropriate answers

- a. Kerosene? I only use this  
I use mostly this  
I use some/a little of this  
I don't use any of this
  
- b. How much kerosene do you use each week?
  
- c. Wax Candles? I only use this  
I use mostly this  
I use some/a little of this  
I don't use any of this
  
- d. How many candles do you use per week?
  
- e. Flashlight (e.g. battery operated or solar)?  
I only use this  
I use mostly this  
I use some/a little of this  
I don't use any of this
  
- f. Something else? What? \_\_\_\_\_  
I only use this  
I use mostly this  
I use some/a little of this  
I don't use any of this

12. How many hours per day do you use indoor lighting? \_\_\_\_\_

13. Who uses the indoor lighting? \_\_\_\_\_

14. What is the indoor lighting used for? Check all that apply

- a. Eating
- b. Children's homework
- c. Recreational reading
- d. Business-related reading
- e. Other work-related activity
- f. Social interaction
- g. Other (specify) \_\_\_\_\_

15. Has anyone in the house experienced a serious burn from flame-based indoor lighting? Circle one. Yes No

- a. If you circled yes, please describe the circumstances of the burn?

#### **Section IV: Respiratory Health History**

This section asks about your health over the last three months.





4. Dizzy/light headed
- ii. Did it start suddenly or gradually? \_\_\_\_\_
  - iii. How long did it last? \_\_\_\_\_
7. In the last 3 months have you had red, itchy, or watery eyes? Circle one.  
Yes      No
- a. If Yes, please describe your experience with red, itchy or watery eyes?
    - i. Other symptoms you had at the same time? \_\_\_\_\_
    - ii. Did it start suddenly or gradually? \_\_\_\_\_
    - iii. How long did it last? \_\_\_\_\_
8. Do you find any of your symptoms got worse after exposure to smoke? Circle one.  
Yes                  No
- a. If Yes – what symptom?
  - b. If Yes – what was the source of smoke exposure?
9. In the last three months have you:
- a. Called for medical advice or assistance?
  - b. Sent an SMS for medical advice or assistance?
  - c. Went to see a medical professional?
  - d. Take any medication for an acute illness?

## A2-2: Household Interview Guide – Runyankole Translation

### Ekicweka kyokubanza: Eka no obutuura bwaayo.

Ekicweka eki nikibuza aha ntuura yeka yawe, ham

we noku eka yawe yakubasa kutunga amashanyarazi.

1. Nooha ari kumaririza okubuzibwa?

Iziina \_\_\_\_\_

Omwanya: \_\_\_\_\_

Omugasho omuka: \_\_\_\_\_

2. Nibaha abarikutuura omuka?

Iziina/nebindi	Emyaaka	Noshorworwa ota	Okakwaate nana kibuzibwa	omurimo

3. Eka yawe eyiine: (yihamu kimwe)

- |  |              |
|--|--------------|
| a. Amashanyarazi gakuruga                        | Yeego Ngaaha |
| b. Aga genereeta?                                | Yeego Ngaaha |
| c. Aga soora?                                    | Yeego Ngaaha |
| d. Ebindi ebyakubaasa kukuheereza amashanyarazi? | Yeego Ngaaha |

4. Kuwakuba wagarukamu ngu “yeego” ahakibuzo 3d naninkushaba kushobororora ahansi:

### Ekicweka kyakabiri: Obulugo bwo omwiika.

Ekicweka eki nikibuza aha miringo entari emwe ne mwe eyiwakubaasa kwisya emyiika etari emwe nemwe.

1. Eka yaawa nokozesa ki kuteeka? Kyebera byoona ebikukozesibwa
  - a. Enku? Ninkozesa eki kyonka  
Ninkozesa eki emirundi emyingi

Ninkozesa kikye aha ryeki  
Tindikozesa kikozeza

- b. Amakara ? Ninkozesa eki kyonka  
Ninkozesa eki emirundi emyingi  
Ninkozesa kikye aha ryeki  
Tindikozesa kikozeza
- c. Ekindi kintu?nikiha?\_\_\_\_\_ ?  
Ninkozesa eki kyonka  
Ninkozesa eki emirundi emyingi  
Ninkozesa kikye aha ryeki  
Tindikozesa kikozeza

- 2. Abi okukozesa kuteeka nebyomunju ninga aheeru(ronda mu)?
  - a. Omunju (bitataine nano omu ryango)
  - b. Omunju (kikwataine no omuryango)
  - c. Aheeru

3. Nooha omuka arikumara obwire ari kuteeka (otiremu esha ezi omuririro gukuba gwakize bwonka)?

Iziina	Ashaaha omwizooba ezokumara otekire

4. nooha omuka eri obwiire bwe omu kiyungu nkomuriro gwo kuteka gwaba gwakize? (obariremu abeka yanyu abatari kuteka nka abaana nana nyinabo)?

Iziina	Esha omuwizooba ezikumarwa omu kishenge kirimu omuriro

5. Hariho ari kureesa omuka yawe?

Iziina	Niki ekikuresibwa(e.g sigara)?	Naharesibwa kiwinganaki omwizooba?	Nibareseza omunju?

**Ekicweka kya kashatu: Esimu nomugasho gwo kumurusya omunzu**  
Ekicweka eki nikibuza aha nkozesa yesimu hamwe nanokumurusya omunju.

- 1. Oyine esimu omuka yaawe? Yihamu kimwe Yeego Ngaaha
  - a. Kwerabe eri “yeego” mwine esimu zingahi omuka engi?

2. Nisente zingahi ezimuri kukozeza aha simu kuteera amasimu?

- a. Ahansi yedakiika ebiri zokuteera esimu omwizooba
- b. Edakiika 2-10 zokuteera esimu omwizooba
- c. Edakiika 10-30 zokuteera esimu omwizooba
- d. Edakiika 30-60 zokuteera esimu omwizooba
- e. Ezirengire omudakiika 60 zokuteera esimu omwizooba

3. Nisente zingahi ezimuri kukozeza kusindika zamesegi (obutumwa)?

- a. Ahansi yomurundi gumwe omwizooba
- b. Omurindi 1-2 omwizooba
- c. Emirundi 2-5 omwizooba
- d. Emirundi 5-10 omwizooba
- e. Erengire aha mirundi 10 omwizooba.

4. Nisente zingahi ezimuri kukozeza kwakira zamesegi (obutumwa)?

- a. Ahansi yomurundi gumwe omwizooba
- b. Omurindi 1-2 omwizooba
- c. Emirundi 2-5 omwizooba
- d. Emirundi 5-10 omwizooba
- e. Erengire aha mirundi 10 omwizooba

5. Esimu nogikozeza ki?

- a. Kuteterera banywani baawe
- b. Kuteterera abeeka
- c. Omasimu gakwasire ahamurimo
- d. Kuhandikira banywani baawe
- e. Kuhandikira abeeka
- f. Kuhandira aba ahamurimo
- g. Okubankinga
- h. Ekindi (kyoreke, kyahuremu) \_\_\_\_\_

6. Okutwariza hamwe ensimu yaawe nogikyaginga ota?

- a. Ahibakwihaho sente kukyaginga esimu.
- b. Omunywani ninga murirwanua aine amashanyarazi.
- c. Omunywani ninga murirwanua aine genereeta
- d. Kyagya ya soola oyomuka
- e. Emyanya endiijo eyine amashanyarazi (gyahuremu)
- f. Emyanya endiijo eyine genereeta (gyahuremu)
- g. Ekindi (kyahuremu) \_\_\_\_\_

7. Nikingahi obu ori kukyaginga esimu yaawe? \_\_\_\_\_

8. Kuwakuba ori owokushashura buri kukyaginga – niki kwetagisa sente zinga kukyaginga esimu yaawe? \_\_\_\_\_

9.Nikitwara obwiire bukwinganaki kukyaginga esimu yaawe (oteiremu obwiire bu orikumara ori kugitwara)?\_\_\_\_\_

10.Orakoziseho esimu yaawe kuterera omushaho, omuzarisa,ninga omuntu webye emibazi weena?

a.Yeego, ndi kuteera esimu

b.Yeego, ndi sindika mesegi(obutumwa)

c. Ngaaha

e. Yaaba eri ngaaha, aha bwaaki?\_\_\_\_\_

11. Eka yaawe nekozesaki kumurika omunju? Toranamu ekikukwataho

a. Parafiini? Niyondikukozesa yonka

Niyondikukozesa obwire obwingi

Ningikozesa kakye

Tindikugikozesa

b. Nokozesa parafiini erikwinganaki buri wiiki?\_\_\_\_\_

c. Kandiro? Niyondikukozesa yonka

Niyondikukozesa obwire obwingi

Ningikozesa kakye

Tindikugikozesa

e.Nokozesa kandiro zingahi omu wiiki?\_\_\_\_\_

f.Tooki (ekyokureberaho. Eza amanda ninga soora)?

Niyondikukozesa yonka

Niyondikukozesa obwire obwingi

Ningikozesa kakye

Tindikugikozesa

12.Neshaha zinga omu izooba ezi orikumara ohembire ekikumurusya omunju?\_\_\_\_\_

13.Nooha erikukozesa ekikumuruka omunju?\_\_\_\_\_

14. Ekikumurika omuju nikikozesibwa ki? (kyebera byona ebikukukwataho)

a. Okurya

b. Homu waaka yabaana

c. Okushoma omubwire bwaawe bwokuhumura

d. Okushoma kukwatsire aha bya bizinesi

e.Nane bindi ebikwatsire aha mirimo

f. Okuganira ahabintu ebyaburijo

e.Nebindi (specify)\_\_\_\_\_

15.Haine omuka yanyu aratungire amasya gamaani go omururo gukuruga aha kumuruka omunju?(ronda mu kimwe) Yeego Ngaaha

a.Waaba watorana yeego,ninkushaba kunshoborora aha bya rugire omu masya ?

**Ekicweka kya kana: Okukuratirira ebyamagara gokwisya**

Ekicweka eki nikibuza aha amagara gaawe omumeezi ashatu agahingwiire.

1. Iziina ryaawe \_\_\_\_\_

2. Omumeezi ashatu agahingwiire wa rwireho? Toranamu kimwe. Yes No

a. Koraabe abaire arwiire ninkushaba kushoborora aha burwiire bwaawe:

i. Okaba oyine bumanyishoki?

ii. Bukandika ryaari?

iii. Bukahendera ryaari?

3. Omumeezi ashatu agahingwiire wakwasirweho orukororo? Toranamu kimwe. Yes No

a. Koraabe obaire oine orukororo, nobaasa kurushoborora ota? Toranamu kimwe.

Orwomire Orworobi Tindikwijuka

i. Kururaabe rwabaire orworobi, ebikororo bikaba nibishushanaki? \_\_\_\_\_

ii. Obundi bumanyiso obuwabeire oyine obwiire obwe? toranamu kyoona ekikukukwataho

1. Okwisya kubi (munonga)

2. Obuzibu omukwiisya

3. Ekizengereera/omutwe mukye

iii. Bukatwaara obweire bukwinganaki? \_\_\_\_\_

4. Omumeezi ashatu agahingwiire wafunire obuzibu omukweisa? toranamu kimwe Yeego

Ngaaha

a. Kwerabe eri yeego, ninkushaba kushoborora nko wafunire obuzibu omukwiisya?

i. Obundi bumanyiso obuwabeire oyine obwiire obwe? toranamu kyoona ekikukukwataho

1. Okwisya kubi (munonga)

2. Okukorora

3. Obuzibu omukwiisya

4. Ekizengereera/omutwe mukye

ii. Kikatandikiraho ninga kikeija mporampora? \_\_\_\_\_

iii. Kikamara obwiire bukwinganaki? \_\_\_\_\_

5. Omumeezi ashatu agahingwiire wafunireho okwisya kubi? Toranamu kimwe Yeego Ngaaha

a. Kwerabe eri yeego, ninkushaba kushoborora nko kuwabaire noyisya kubi?

i. Obundi bumanyiso obuwabeire oyine obwiire obwe? toranamu kyoona ekikukukwataho

1. Obuzibu omukwiisya

2. Okukorora

3. Obusaasi (Shoborora nkahi?)

4. Ekizengereera/omutwe mukye

ii. Kikatandikiraho ninga kikeija mporampora? \_\_\_\_\_

iii. Kikamara obwiire bukwinganaki? \_\_\_\_\_

6. Omumeezi ashatu agahingwiire watungireho okushasha kwa ahamumiro? Toranamu

kimwe Yeego Ngaaha

a. Kukiraabe kiri yeego, ninkushaba kushoborora aha kushasha kwawe kwo omumiro?

i. Obundi bumanyiso obuwabeire oyine obwiire obwe? toranamu kyoona ekikukukwataho

1. Okwisya kubi (munonga)

2. Okukorora

3. Obuzibu omukwiisya

4. Ekizengereera/omutwe mukye

ii. Kikatandikiraho ninga kikeija mporampora? \_\_\_\_\_

iii. Kikamara obwiire bukwinganaki? \_\_\_\_\_

7. Omumeezi ashatu agahingwiire watungireho okutukura,okuryaana,okurira kwa amisho?

i. Obundi bumanyiso obuwabeire oyine obwiire obwe? \_\_\_\_\_

ii. Kikatandikiraho ninga kikeija mporampora? \_\_\_\_\_

iii. Kikamara obwiire bukwinganaki? \_\_\_\_\_

8.Haine obu orikushanga bumwe aha bumanyiso bwawe buri kweyongera waheza kwiitwa omwiika? Toranamu kimwe Yeego Ngaaha

a.Kyaba kiri yeego-nibumanyiso ki?

b. Kyaba kiri yeego-omwika gukaba niguruga nkahi?

9. Omumeezi ashatu agahingwiire :

a.Wayesire obuhabuzi ninga obuyanbi kuruga omu bobushaho?

b.Wasindikire obutumwa kuntunga obuhabuzi ninga obuyanbi bwe obyobushaho?

c.Wagire kureba awe ebyobushaho?

d.Wamizire omubazi gwoona gwoburweire?|



### A3-1: Most Frequent Microbes Found in Electrode Communities

**Table A3-1-1.** Top 20 microbes identified in communities at anodes of cells fed with blood meal fed and those fed with just the topsoil inoculate. Grey cells are those that appear in only one of the two anodes sequenced.

Topsoil - 2 Anode	Topsoil - 3 Anode	Blood Meal 4 - Anode	Blood Meal 1 - Anode
Anaerolinea thermophila	Anaeromyxobacter dehalogenans	Achromobacter xylosoxidans	Acidovorax sp. JS42
Bradyrhizobium japonicum	Bradyrhizobium japonicum	Bacteroides fragilis	Bacteroides fragilis
Bradyrhizobium sp.	Bradyrhizobium sp.	Bacteroides sp.	Bacteroides sp.
Bradyrhizobium sp. BTAi1	Bradyrhizobium sp. BTAi1	Bacteroides sp. 2_1_33B	Bacteroides sp. 2_1_33B
Candidatus Koribacter versatilis	Candidatus Koribacter versatilis	Bacteroides sp. 2_1_7	Bacteroides sp. 2_1_7
Candidatus Solibacter usitatus	Candidatus Solibacter usitatus	Bacteroides sp. 3_1_19	Bacteroides sp. 3_1_19
Chitinophaga pinensis	Dechloromonas aromatica	Bacteroides thetaiotaomicron	Bacteroides thetaiotaomicron
Dechloromonas aromatica	Geobacter metallireducens	Brevundimonas sp. BAL3	Bacteroides vulgatus
Geobacter bemidjiensis	Geobacter sp.	Brevundimonas subvibrioides	Brevundimonas sp. BAL3
Geobacter metallireducens	Geobacter sulfurreducens	Caulobacter vibrioides	Brevundimonas subvibrioides
Geobacter sp.	Geobacter uraniireducens	Comamonas testosteroni	Comamonas testosterone
Geobacter sulfurreducens	Mesorhizobium loti	Delftia acidovorans	Flavobacterium johnsoniae
Geobacter uraniireducens	Myxococcus xanthus	Flavobacteriaceae bacterium 3519-10	Paludibacter propionicigenes
Mesorhizobium loti	Novosphingobium aromaticivorans	Flavobacterium johnsoniae	Parabacteroides distasonis
Opitutus terrae	Opitutus terrae	Parabacteroides distasonis	Parabacteroides johnsonii
Pedosphaera parvula	Pedosphaera parvula	Parabacteroides johnsonii	Parabacteroides merdae
Pelobacter propionicus	Pelobacter propionicus	Parabacteroides merdae	Parabacteroides sp. D13
Rhizobium leguminosarum	Rhizobium leguminosarum	Parabacteroides sp. D13	Pedobacter heparinus
Rhodopseudomonas palustris	Rhodopseudomonas palustris	Pedobacter heparinus	Porphyromonas gingivalis
Sorangium cellulosum	Sorangium cellulosum	Sphingobacterium spiritivorum	Sphingobacterium spiritivorum

**Table A3-1-2.** Top 20 species by frequency found in communities at anodes in fish-meal-fed cells. Bold type indicates presence in all 4 electrodes sequenced. Italic type indicates presence in 3 of the 4 anodes sequenced. Grey cells indicate the species is found in the top 20 species of a single anode community only.

<b>Fish Meal – 1 Anode</b>	<b>Fish Meal – 2 Anode</b>	<b>Fish Meal – 4 Anode</b>	<b>Fish Meal – 5 Anode</b>
Achromobacter piechaudii	Achromobacter piechaudii	<b>Achromobacter xylooxidans</b>	<b>Achromobacter xylooxidans</b>
<b>Achromobacter xylooxidans</b>	<b>Achromobacter xylooxidans</b>	<b>Acinetobacter baumannii</b>	<i>Acidovorax</i> sp. JS42
<i>Acidovorax</i> sp. JS42	Acidovorax citrulli	Acinetobacter lwoffii	<b>Acinetobacter baumannii</b>
<b>Acinetobacter baumannii</b>	<i>Acidovorax</i> sp. JS42	Acinetobacter sp.	<i>Bacteroides fragilis</i>
Arcobacter butzleri	<b>Acinetobacter baumannii</b>	Acinetobacter sp. ADP1	<b>Bacteroides</b> sp.
<i>Bacteroides fragilis</i>	Acinetobacter johnsonii	<i>Bacteroides fragilis</i>	Bacteroides sp. 2_1_7
<b>Bacteroides</b> sp.	Acinetobacter lwoffii	<b>Bacteroides</b> sp.	Bacteroides sp. 3_1_19
Bacteroides sp. 3_1_19	Acinetobacter sp.	<i>Bordetella bronchiseptica</i>	Bacteroides thetaiotaomicron
Bacteroides thetaiotaomicron	Acinetobacter sp. ADP1	<i>Bordetella parapertussis</i>	Bacteroides vulgatus
Bacteroides vulgatus	<b>Bacteroides</b> sp.	<b>Comamonas testosteroni</b>	<b>Comamonas testosteroni</b>
Bordetella avium	Bordetella avium	<b>Delftia acidovorans</b>	<b>Delftia acidovorans</b>
<i>Bordetella bronchiseptica</i>	<i>Bordetella bronchiseptica</i>	<i>Methanoculleus marisnigri</i>	<i>Methanoculleus marisnigri</i>
<i>Bordetella parapertussis</i>	<i>Bordetella parapertussis</i>	Methanosarcina barkeri	Methanosarcina barkeri
Bordetella pertussis	<b>Comamonas testosteroni</b>	<b>Parabacteroides distasonis</b>	Paludibacter propionicigenes
Bordetella petrii	<b>Delftia acidovorans</b>	<i>Pseudomonas aeruginosa</i>	<b>Parabacteroides distasonis</b>
<b>Comamonas testosteroni</b>	<i>Methanoculleus marisnigri</i>	<i>Pseudomonas fluorescens</i>	Parabacteroides sp. D13
<b>Delftia acidovorans</b>	<b>Parabacteroides distasonis</b>	<i>Pseudomonas mendocina</i>	<i>Pseudomonas aeruginosa</i>
Paludibacter propionicigenes	<i>Pseudomonas aeruginosa</i>	<i>Pseudomonas putida</i>	<i>Pseudomonas fluorescens</i>
<b>Parabacteroides distasonis</b>	<i>Pseudomonas mendocina</i>	<i>Pseudomonas stutzeri</i>	<i>Pseudomonas mendocina</i>
Parabacteroides sp. D13	<i>Pseudomonas stutzeri</i>	<i>Pseudomonas syringae</i>	<i>Pseudomonas stutzeri</i>

**Table A3-1-3. Top 10 species appearing in populations at each cathode.**

<b>Rank</b>	<b>Blood Meal – 1 Cathode</b>	<b>Blood Meal – 2 Cathode</b>	<b>Blood Meal – 3 Cathode</b>	<b>Blood Meal – 4 Cathode</b>
1	Methanoculleus marisnigri	Comamonas testosteroni	Comamonas testosteroni	Methanoculleus marisnigri
2	Comamonas testosteroni	Stenotrophomonas maltophilia	Geobacter metallireducens	Comamonas testosteroni
3	Acinetobacter baumannii	Brevundimonas subvibrioides	Delftia acidovorans	Acinetobacter baumannii
4	Delftia acidovorans	Acidovorax sp. JS42	Achromobacter xylosoxidans	Delftia acidovorans
5	Flavobacteriaceae bacterium 3519-10	Xanthomonas campestris	Acidovorax sp. JS42	Parabacteroides distasonis
6	Methanosarcina barkeri	Delftia acidovorans	Bacteroides sp.	Acinetobacter sp. ADP1
7	Acidovorax sp. JS42	Brevundimonas sp. BAL3	Brevundimonas subvibrioides	Acinetobacter sp.
8	Acinetobacter sp. ADP1	Mesorhizobium loti	Acidovorax citrulli	Flavobacteriaceae bacterium 3519-10
9	Xanthomonas campestris	Acidovorax citrulli	Bordetella bronchiseptica	Acinetobacter johnsonii
10	Acinetobacter sp.	Achromobacter xylosoxidans	Parabacteroides distasonis	Bacteroides sp.

<b>Rank</b>	<b>Fish Meal – 1 Cathode</b>	<b>Fish Meal – 2 Cathode</b>	<b>Fish Meal – 4 Cathode</b>	<b>Fish Meal – 5 Cathode</b>
1	Comamonas testosteroni	Geobacter metallireducens	Comamonas testosteroni	Comamonas testosteroni
2	Dechloromonas aromatica	Geobacter sulfurreducens	Bacteroides sp.	Delftia acidovorans
3	Delftia acidovorans	Bacteroides sp.	Parabacteroides distasonis	Acidovorax sp. JS42
4	Acidovorax sp. JS42	Parabacteroides distasonis	Delftia acidovorans	Acidovorax citrulli
5	Acinetobacter baumannii	Dechloromonas aromatica	Flavobacteriaceae bacterium 3519-10	Acidovorax avenae
6	Brevundimonas subvibrioides	Sphingopyxis alaskensis	Sphingopyxis alaskensis	Sphingobacterium spiritivorum
7	Stenotrophomonas maltophilia	Chitinophaga pinensis	Sphingobacterium spiritivorum	Verminephrobacter eiseniae
8	Geobacter metallireducens	Bacteroides fragilis	Dechloromonas aromatica	Bacteroides sp.
9	Acidovorax citrulli	Stenotrophomonas maltophilia	Chitinophaga pinensis	Brevundimonas subvibrioides
10	Sphingopyxis alaskensis	Comamonas testosteroni	Acidovorax sp. JS42	Dechloromonas aromatica

<b>Rank</b>	<b>Topsoil 1 – Cathode</b>	<b>Topsoil 2 – Cathode</b>	<b>Topsoil 3 – Cathode</b>
1	Rhodopseudomonas palustris	Rhodopseudomonas palustris	Opitutus terrae
2	Candidatus Solibacter usitatus	Dechloromonas aromatica	Candidatus Solibacter usitatus
3	Dechloromonas aromatica	Opitutus terrae	Rhodopseudomonas palustris
4	Opitutus terrae	Candidatus Solibacter usitatus	Bradyrhizobium japonicum
5	Bradyrhizobium japonicum	Bradyrhizobium japonicum	Sorangium cellulosum
6	Bradyrhizobium sp.	Bradyrhizobium sp.	Bradyrhizobium sp.
7	Sorangium cellulosum	Sorangium cellulosum	Chitinophaga pinensis
8	Gemmatimonas aurantiaca	Bradyrhizobium sp. BTAi1	Pedosphaera parvula
9	Hyphomicrobium denitrificans	Gemmatimonas aurantiaca	Bradyrhizobium sp. BTAi1
10	Bradyrhizobium sp. BTAi1	Mesorhizobium loti	Candidatus Koribacter versatilis

### A3-2: Fractions Unassignable Bacterial Sequences By Electrode

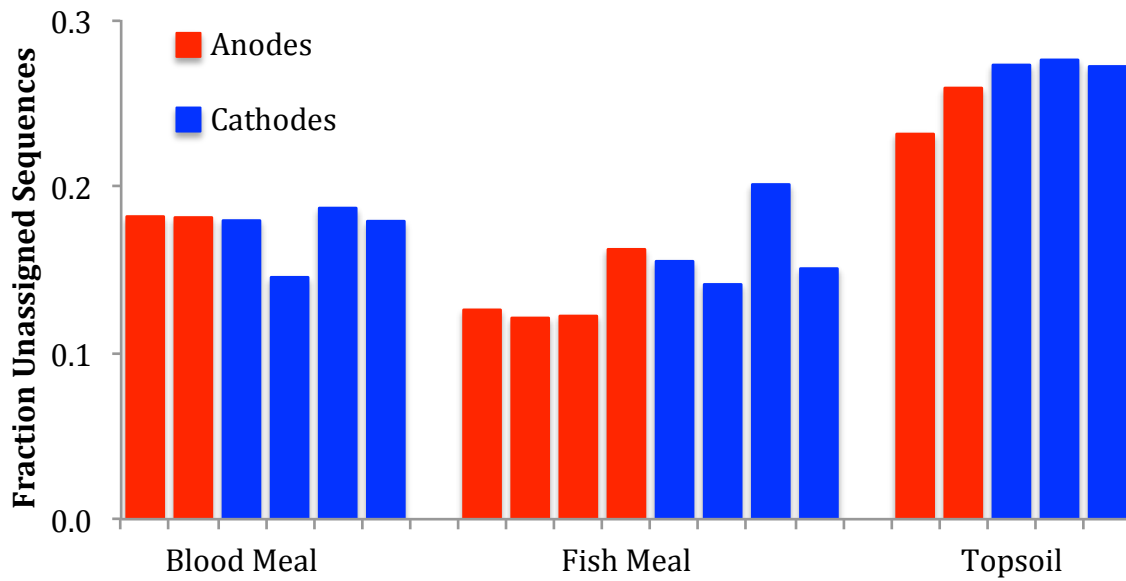

**Figure A3-2-1. On average, 19% of bacterial sequences generated from each electrode are unassignable with MG-RAST. The values are roughly consistent across electrode type and feed type.**

#### A4-1: Detailed illustrations of modular MFCs

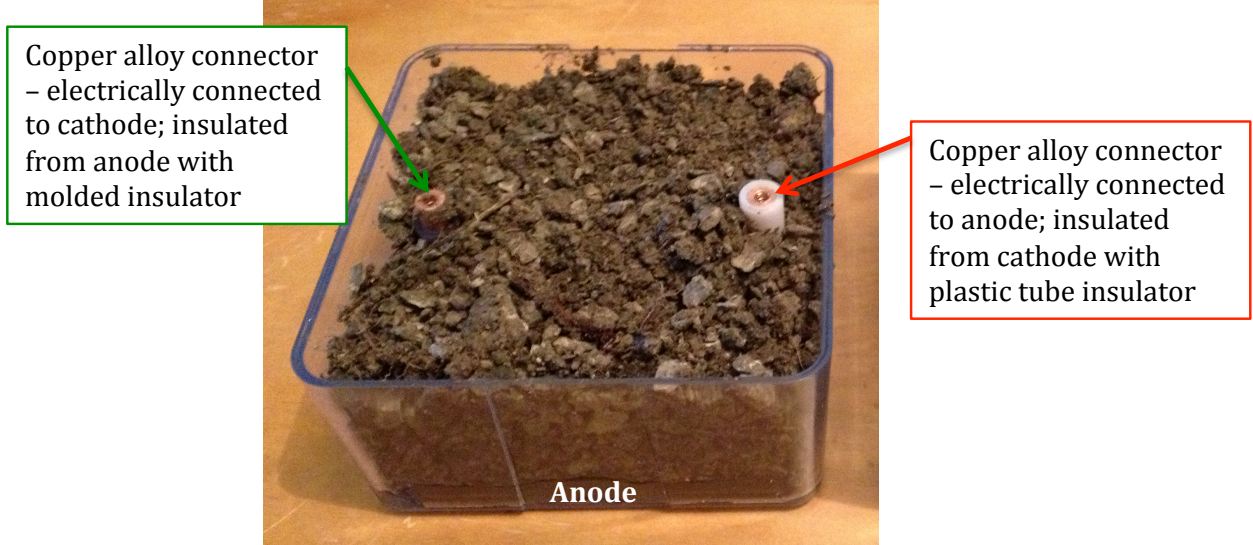
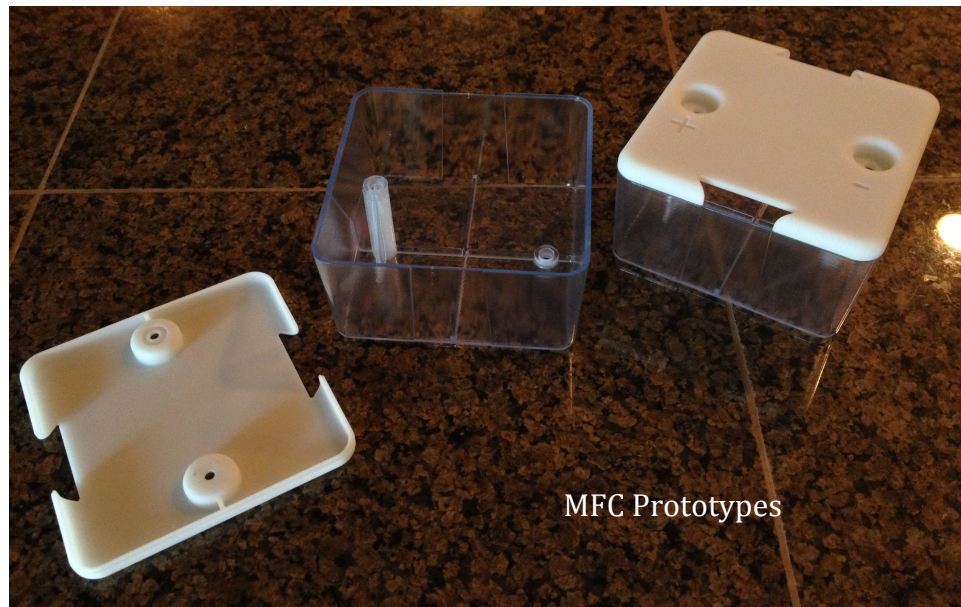

Bottom of copper connector extends out of the housing and has an opening that can fit a standard banana plug



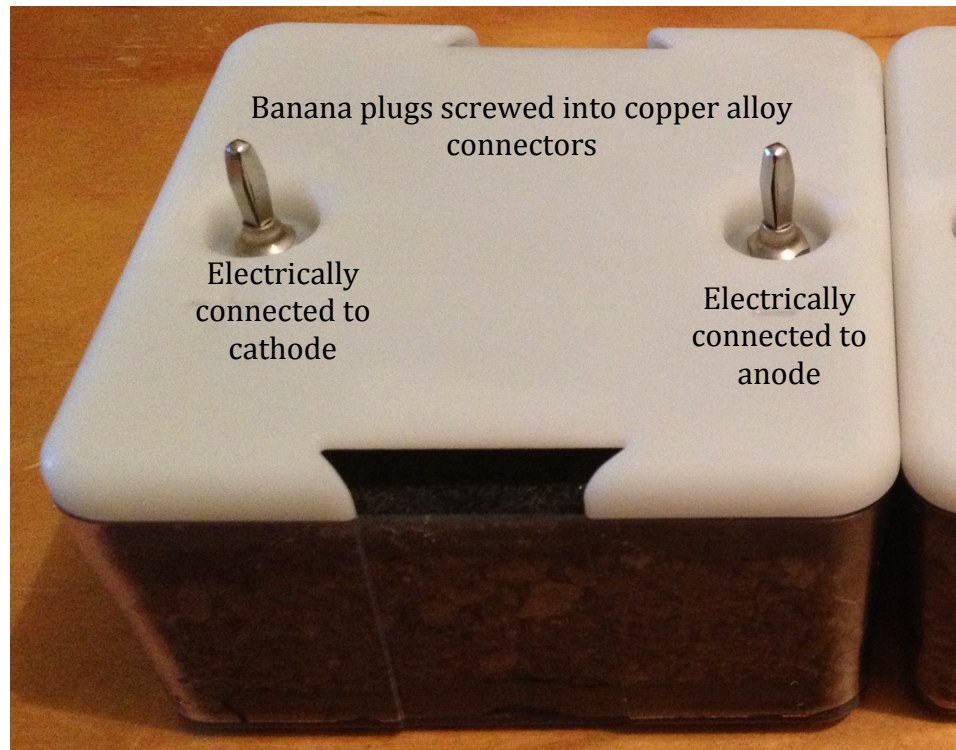
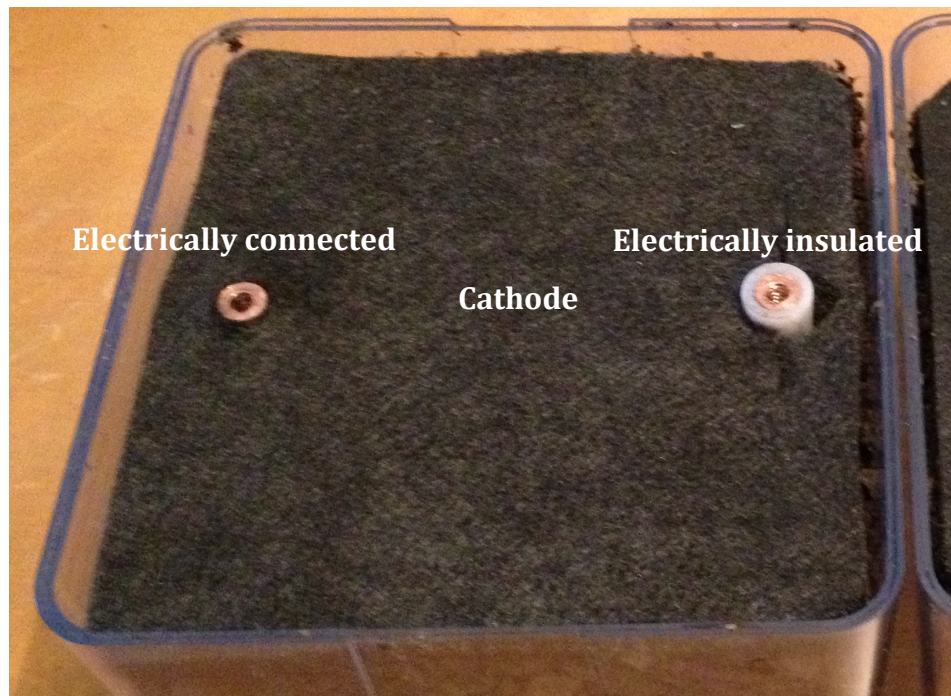

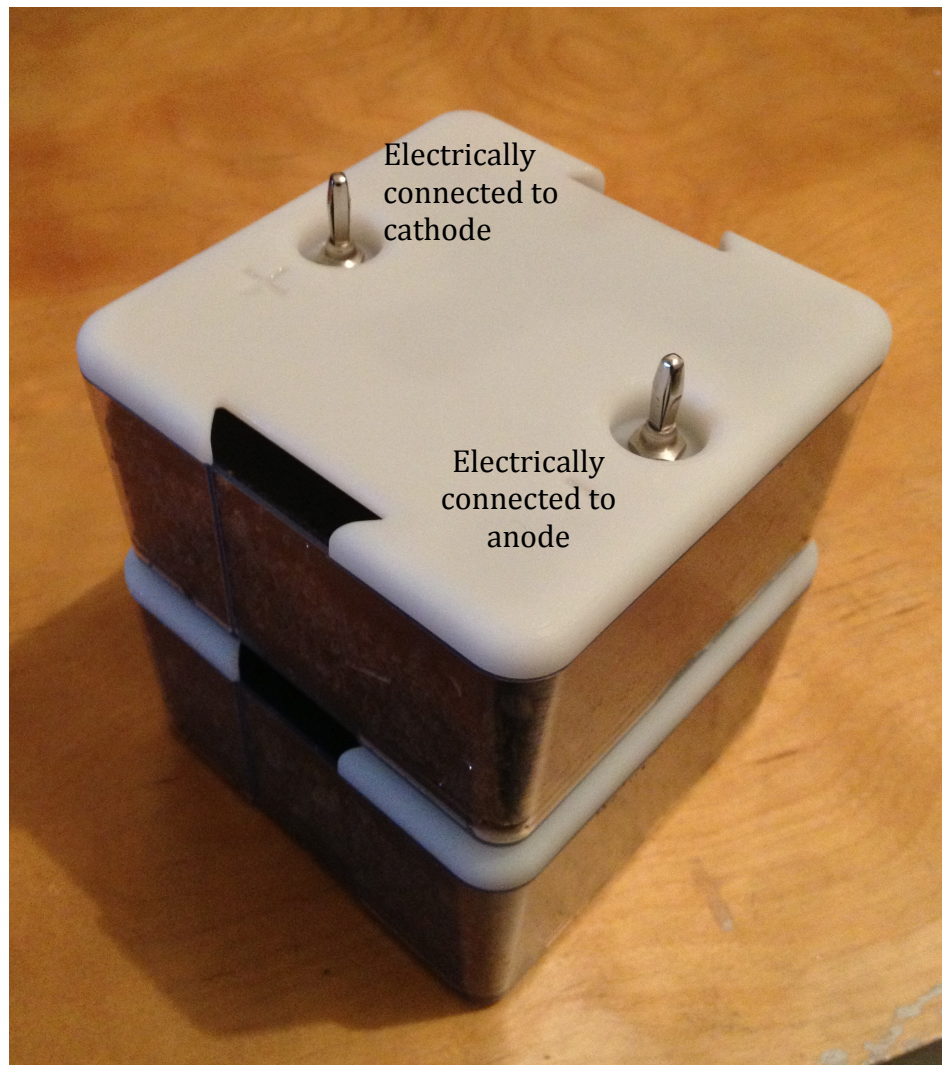

Anode banana plug on cell n plugs into copper connector base of cell n+1. Cathode banana plug on cell n plugs into copper connector base of cell n+1