



The Demoiselles d'Evanston: On the Aesthetics of the Wigmore Chart

Citation

Bruce L. Hay, The Demoiselles d'Evanston: On the Aesthetics of the Wigmore Chart, 73 Law, Probability & Risk 211 (2008).

Published Version

doi: 10.1093/lpr/mgn003

Permanent link

<http://nrs.harvard.edu/urn-3:HUL.InstRepos:11998341>

Terms of Use

This article was downloaded from Harvard University's DASH repository, and is made available under the terms and conditions applicable to Open Access Policy Articles, as set forth at <http://nrs.harvard.edu/urn-3:HUL.InstRepos:dash.current.terms-of-use#OAP>

Share Your Story

The Harvard community has made this article openly available.
Please share how this access benefits you. [Submit a story](#).

[Accessibility](#)

Les Demoiselles d'Evanston: On the Aesthetics of the Wigmore Chart

Bruce L. Hay

Harvard Law School, Cambridge, MA 02138, USA[†]

Forthcoming, *Law, Probability and Risk* (fall 2008)

*There is an old adage that the Investigating Officer can often remember to good purpose, namely, "Cherchez la femme," "Seek for the woman."*¹

I

The International Exhibition of Modern Art arrived at the Art Institute of Chicago in March 1913, a few months before John Wigmore of Northwestern University published the *The Problem of Judicial Proof*, in which he introduced his "chart method" of analyzing and evidence.² Known as the Armory Show, the exhibition was billed as America's first big introduction to Cubism, Fauvism, Futurism, and the other fashionable isms of the contemporary European art scene.³ ("Splash! Splotch! Cubist Art Here," one Chicago newspaper headline

[†] Email: bruce_hay@harvard.edu.

AUTHOR'S NOTE: This paper was originally presented at a conference on Graphic and Visual Representations of Evidence at Cardozo Law School, most papers from which were published in a special issue of *Law, Probability & Risk* in December 2007. I thank Peter Tillers for organizing the conference and including me.

¹ GROSS, H. (1924). *Criminal Investigation: A Practical Textbook for Magistrates, Police Officer and Lawyers*. London: Sweet & Maxwell, ___.

² WIGMORE, J. (1913) *The Problem of Proof*. *Illinois Law Review*, **8**, 83. Portions of the articles were taken from his book, WIGMORE, J. (1913). *The Principles of Judicial Proof as Given by Logic, Psychology, and General Experience and Illustrated in Judicial Trials*. Boston: Little, Brown.

³ The exhibition opened in New York's 69th Regiment Armory in February 1913, featuring about 1,250 paintings, sculptures and decorative objects by about 300 European and American artists. About half of those works traveled

announced, following the popular press's custom of using "cubist" as an umbrella term to designate all of the strange new styles.⁴) It is intriguing to speculate (for I have been unable to determine) whether Wigmore attended the exhibition, and if so whether he saw any connection between the art on display there and the schematic diagrams in his *Judicial Proof* article, which came out in June of that year. If he did see a connection it was, to his mind, probably negative. Wigmore was enormously learned and had a wide-ranging knowledge of many cultures, but his leanings were had Victorian. He would have considered his chart method, designed as it was for the orderly administration of justice, as being firmly opposed to the decadence, libertinism, anarchism, bolshevism, and sheer mental derangement that many traditionalists discerned in the works of Matisse, Gauguin, Duchamp, Picasso, and other artists of what the newspapers called the "advance guard."

Indeed, Wigmore presented his method as a self-conscious reaction to what he saw as the disorder reigning in the continental legal systems. What America needs, he says in his 1913 article, is "a probative science – the principles of proof – independent of the artificial rules of procedure."⁵ If we fail to develop one, "we shall find ourselves in the present plight of Continental Europe," where in the previous century "the ancient

to Chicago and then to Boston. For a general account of the exhibition, see BROWN, M. (1988). *The Story of the Armory Show*. New York: Abbeville Press.

⁴ *Chicago Daily Tribune*, 23 March 1913, p. 1.

⁵ The Wigmore quotations in this paragraph are from *The Problem of Proof*, supra note 1, pp. 77-78.

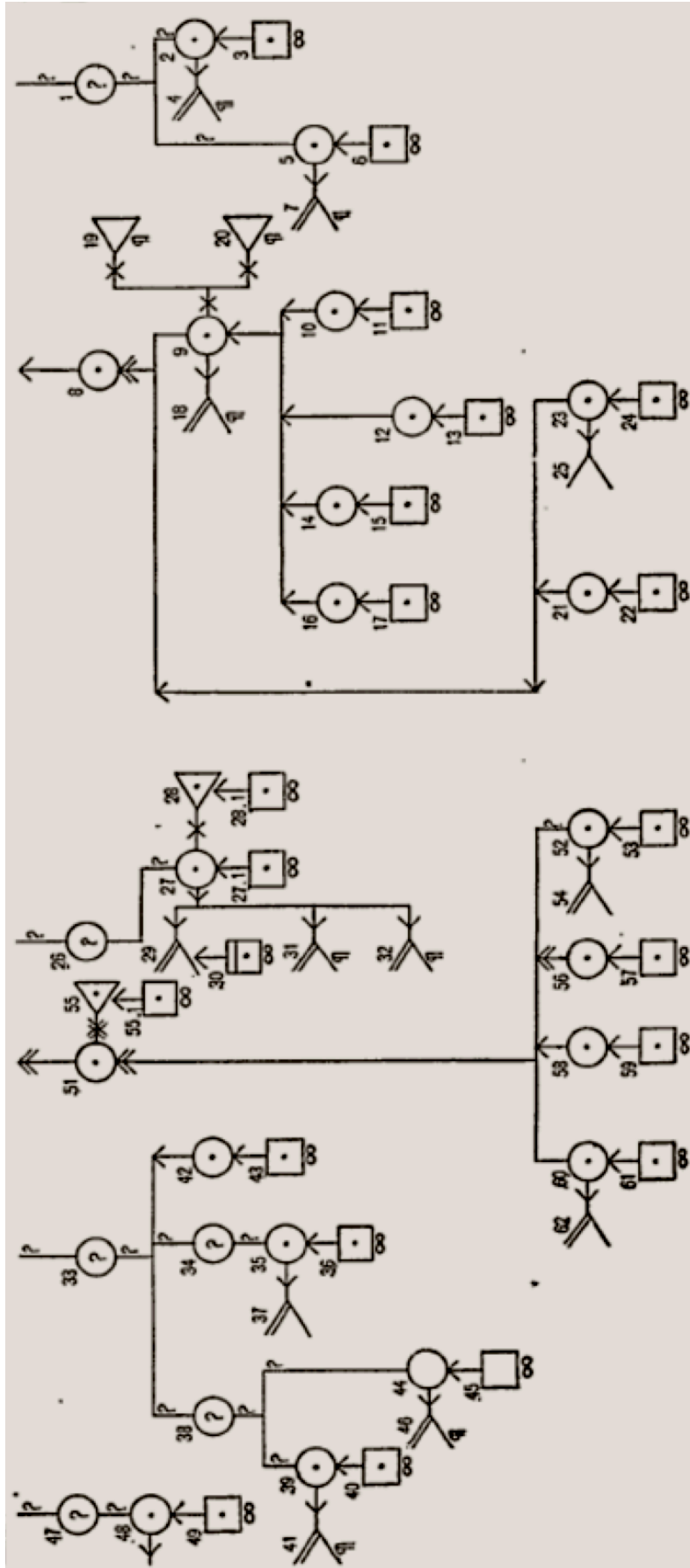

Figure 1. Wigmore, *Chart of the Evidence in Commonwealth v. Umilian*. 1913.
 From *The Problem of Proof*

worn-out numerical system of ‘legal proof’ was abolished by fiat and the so-called ‘free proof’ – namely, no system at all – was substituted.” European jurists, he explains, never acquired an “understanding of the living process of belief; in consequence, when ‘legal proof’ was abolished, they were unready, and judicial trials have been carried on for a century past by uncomprehended, unguided, and therefore unsafe mental processes.” He makes *free proof* sound like the juridical equivalent of free love; his talk of “unsafe mental processes” echoes what the guardians of public morals in Chicago are saying about the strange, unconventional nudes at the Armory Show. “Nasty, lewd, immoral, and indecent,” one schoolteacher declares; do not expose the young to these “degeneracies of Paris,” a clergyman warns.⁶ “The idea that some people can gaze at this sort of thing without its hurting them is all bosh. This exhibition ought to be suppressed,” says the president of the city’s Law and Order League. And newspaper calls the work “pollution . . . materialized in several paintings of the nude; portrayals that unite in an insult to the great, self-respecting public of Chicago. Just who is responsible for this showing of dishonor to sensitive great art that finds expression in the chaste and beautiful painting of the human figure in the nude in our Institute?” And a speaker at a ladies’ group in Evanston intones: “The body is the temple of God, and the cubists have profaned

⁶ The remaining quotations in this paragraph are taken from *The Story of the Armory Show*, supra note 2, p. 206.

the temple.”⁷ Whatever Wigmore’s one views on the exhibition were, it is unlikely he thought it had much in common with his own work.

Still, certain parallels between his chart method and artistic modernism are hard to resist. His project should, I think, be seen as part of the response to the “crisis of representation” making itself felt in many forms of cultural production at the time. Think of the year 1913 alone:⁸ Russell and Whitehead complete the *Principia Mathematica*, providing what they think will be a firm logical foundation for mathematics; Wittgenstein begins the correspondence concerning Russell’s theory of knowledge that will result in the *Tractatus*; Saussure dies, prompting the publication of his *Cours de Linguistique Generale* from student notes; in the legal academy, Hohfeld publishes his *Fundamental Legal Conceptions as Applied in Judicial Reasoning*. In the arts, the *Rite of Spring*, composed by Stravinsky and choreographed by Nijinsky, sparks a riot at its premiere in Paris; Malevich paints his *Black Square*, thought by some art historians to be the first purely abstract painting in western art; Joyce’s *Portrait of the*

⁷ Not all Chicagoans had such narrow-minded reactions. Many were enthusiastic about the new styles; others were skeptical, but urged “fair play for insurgent art,” as one Chicago newspaper put it. See *The Story of the Armory Show*, supra note 1, at 179. See also Martinez, A. (19__). A Mixed Reception for Modernism: The 1913 Armory Show at the Art Institute of Chicago. *Museum Studies*, 19, 30; PRINCE, S. (1990). Chicago Critics Take on Modernism. *The Old Guard and the Avante-Garde: Modernism in Chicago, 1910-40* (S. Prince ed.), pp. 98-102. On responses to the exhibition across the country, see MANCINI, J.M. (1999). “One Term is as Fatuous as Another”: Responses to the Armory Show Reconsidered. *American Quarterly*, 51, 833.

⁸ I am indebted to Neal Feigensohn for some of the examples in the paragraph. A recent treatment of that year’s achievements is Rabaté, J. (2007). *1913: The Cradle of Modernism*.

Artist as a Young Man is serialized, the first volume of the Proust's *A la recherche du temps perdu* is published, and Virginia Woolf completes her first novel. In their different way each of these works, like Wigmore's method, is a self-conscious effort to develop a new language for its aesthetic or intellectual domain. The Wigmore article doesn't make the splash these other works do, but that shouldn't keep us from viewing it in their company.

The Wigmore chart system, as Peter Tillers has remarked, is an important precursor to current research on the visual representation of information, and for that reason deserves the attention of anyone interested in the subject of the recent symposium in these pages on visual evidence.⁹ The analytical properties of the Wigmore system have been well explored by a number of scholars who have approached it from the perspective of cognitive science, demonstrating its potential value for drawing correct inferences from disaggregated bits of information.¹⁰ I am a fan of this work, being partial to the use of visual diagrams and also to the

⁹ See TILLERS, P. (2007). Introduction: Visualizing Evidence and Inference in Legal Settings. *Law, Probability & Risk*, **6**, 4. Wigmore's system has been mostly ignored by evidence scholars, who view it in rather the same way traditionalists saw the artistic avant-garde work of the period: as weird and illegible. The difference, of course, is that the avant-garde works of that era have now become mainstream, while the the Wigmore article is still generally seen as a "quaint, even bizarre, period piece," as William Twining characterizes the prevailing attitude. TWINING, W. (1985). *Theories of Evidence: Bentham and Wigmore*. Stanford: Stanford University Press, p. 165..

¹⁰ The Wigmore system has only received the sustained attention of a few scholars, most of them writing after the 1970s. See, for example, SCHUM, D. AND MARTIN, A. (1982). Formal and Empirical Research on Cascaded Evidence. *Law and Society Review*, **17**, 105; *Theories of Evidence*, supra; TILLERS, P. and SCHUM, D. (1988). Charting New Territory in Judicial Proof: Beyond Wigmore. *Cardozo Law Review*, **9**, 907; ANDERSON, T. AND TWINING, W. (1991). *Analysis of Evidence: How to Do Things with Facts, Based on Wigmore's Science of Proof*. Boston: Little Brown.

study of rational decision making. But I am also a believer in the close reading of images, and wonder whether we students of the Wigmore system have not overlooked some of the meanings embedded in its outwardly formal, abstract language of primitive shapes. With that possibility in mind, I propose – somewhat irreverently – to examine the Wigmore system from an aesthetic and vaguely psychoanalytic point of view, comparing it to another, better known geometric system of representation that also made its Chicago debut in that spring of 1913. My reflections here should not be taken as a judgment on the general project of developing tools for the visual analysis and representation of evidence, a project with which (to repeat) I am quite sympathetic. Rather, they should be taken as a reminder that if we are to understand visual evidence, we need to learn to look carefully at what we are seeing.

II

I would liken the Wigmore method to the aesthetic of Picasso's *Standing Female Nude*, which traveled to Chicago with the Armory Show and now hangs in the permanent collection of the Museum of Modern Art in New York.¹¹ A charcoal drawing done in 1910, this work is typical of the so-called analytic phase of cubism, with its characteristic monochrome palette,

¹¹ I should note that this work did not attract the condemnations lavished on the paintings of Duchamp, Gauguin, and especially Matisse (whose paintings were burned in effigy).

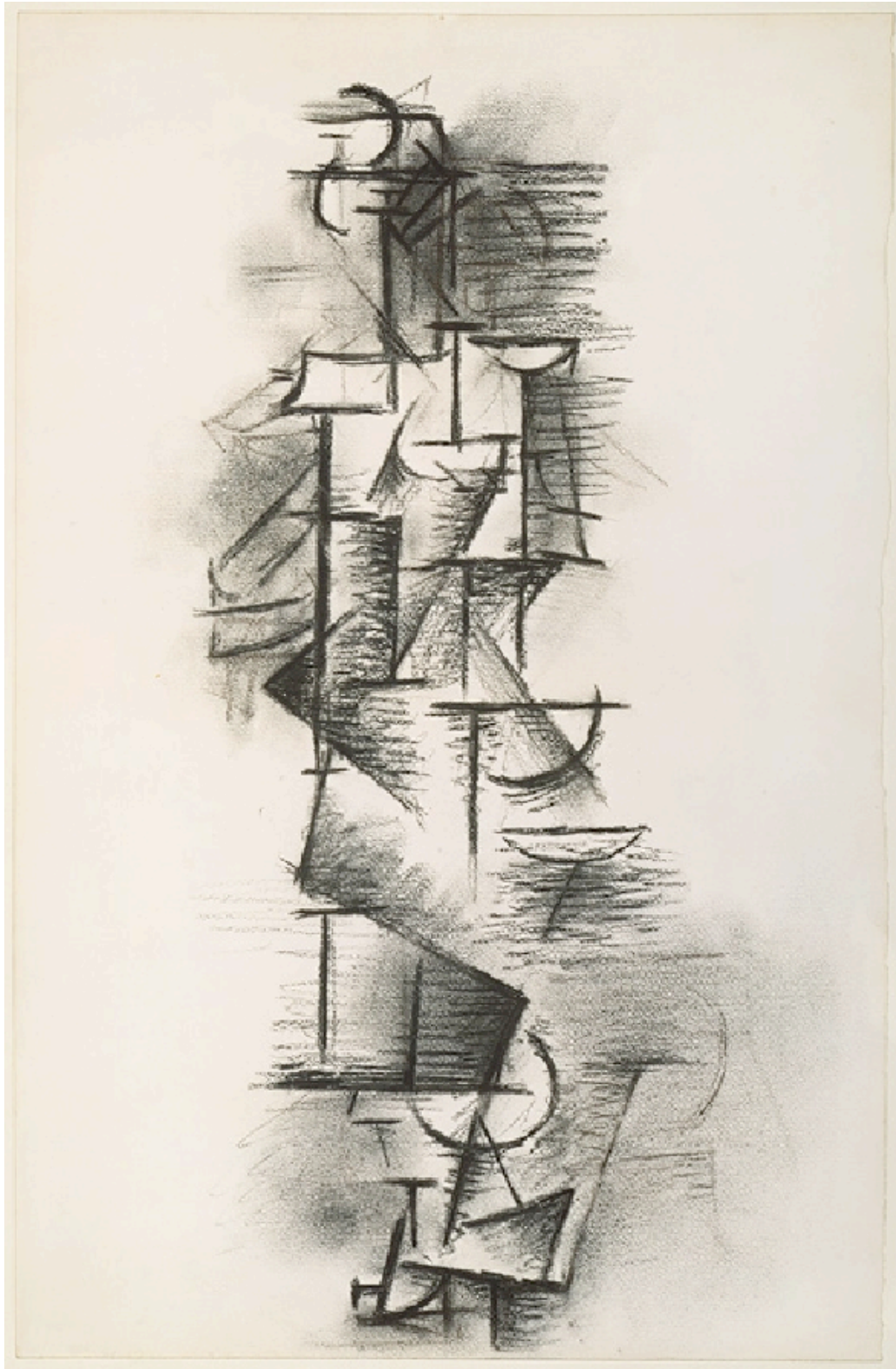

Figure 2. Pablo Picasso, *Standing Female Nude*. 1910.
Metropolitan Museum of Art, New York.

multiple planes, and reduction of its subject to simple lines, curves and angles.¹² Nearby the Picasso I have reproduced the two complete charts Wigmore included in his *Judicial Proof* article as examples of his method; both are his own diagrams of the evidence in a murder case (figures 1 and 3). The charts employ the elaborate system of symbols Wigmore has developed in the article – closed circles and boxes, respectively, for “affirmatory” testimonial and circumstantial evidence; open boxes and circles, respectively, for “negatory” testimonial and circumstantial evidence; triangular objects for “explanatory” and “corroborative” evidence; an assortment of lines, arrows, squiggles and dots to indicate the source of the evidence, the degree of its perceived credibility, the conclusion toward which it points, and other things (figure 4). Of the cubist painters, a contemporary admirer said that soon they will have “created the algebra of painting,” by which they will “separate out – according to their own own analytical methods and to the characteristics of the object – the principal elements of the bodies they propose to translate.”¹³ He might almost have been speaking of Wigmore’s algebra

¹² The analytic phase of cubism is usually dated to the period 1910-1912. The “synthetic” phase is said to have started in late 1912 when Braque and Picasso started using collage techniques to construct images out of newspapers, string, and other objects.

¹³ From critic Maurice Raynal’s catalog for a June 1912 modern art exhibition in Rouen. The English translation here is taken from FRY, E. (1966), *Cubism*. London: Thames & Hudson, p. 92.

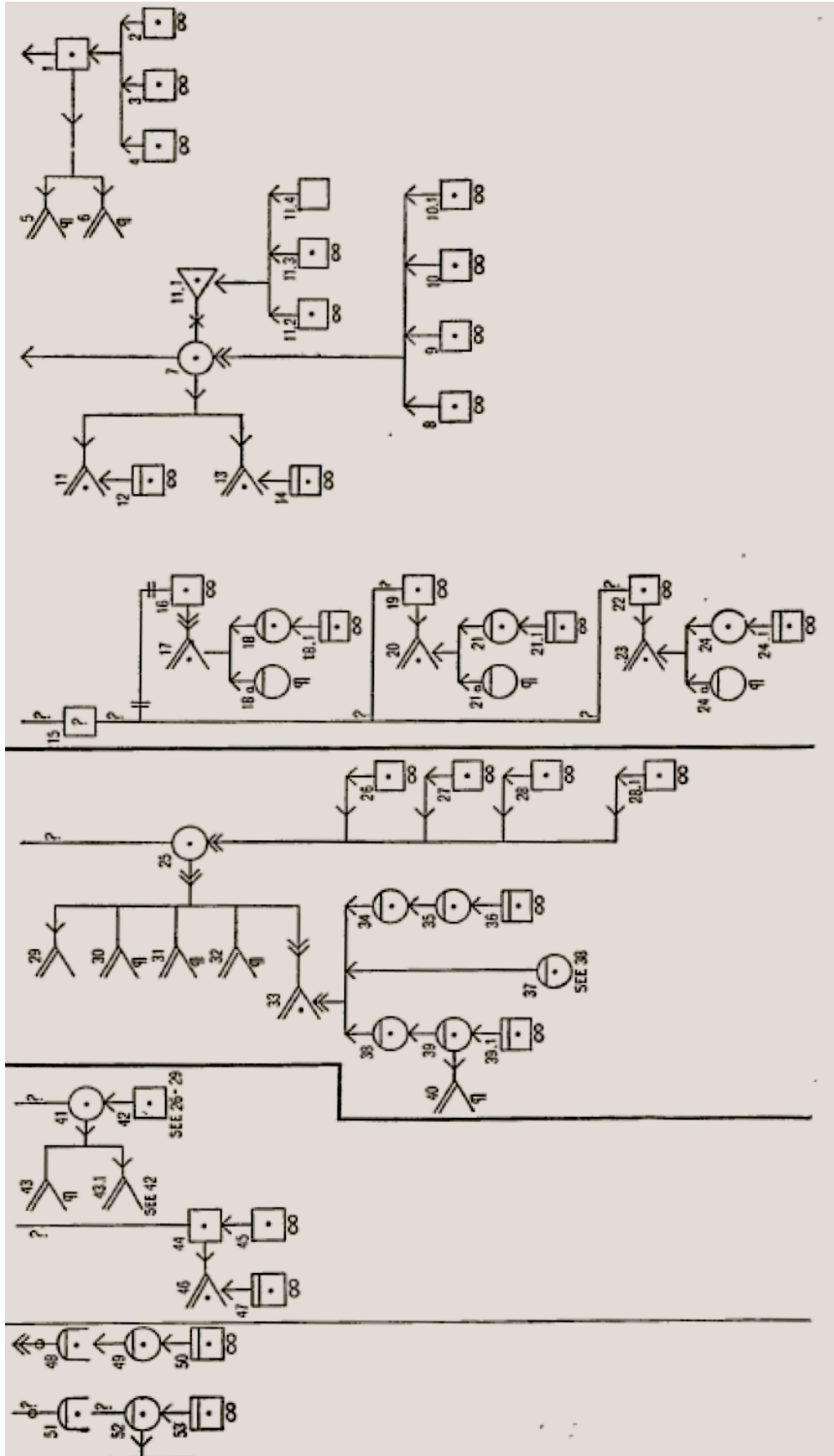

Figure 3. Wigmore, *Evidence Chart for Hatchett v. Commonwealth*. 1913
 From *The Problem of Proof*

of evidence. The lexicon of geometric shapes in the Wigmore chart has a surprising resemblance to that of the Picasso drawing, though obviously their terms of reference – one represents the physical world, the other purely abstract relations among thoughts – are very different.

There is also a remarkable congruence in the problems of representation the two figures are designed to address. Sympathetic critics around 1913 are praising cubism for, among many other things, compressing more information into an image than could be achieved by conventional pictorial techniques.¹⁴ Where conventional painting gives just a partial view of an object, showing it from one side only, cubism can show the object from many sides at once; where conventional painting froze time at a single moment, cubism could capture successive moments in a single image.¹⁵ In cubism, one writer claims, the aim is to “depict the object as one knows it is – that is, from several angles at one time[,] ... yielding a complete representation of the object”;

¹⁴ In comparing the critics’ theories of cubism to the Wigmore’s rationale for the chart system, I confine myself to some of the critical views circulating in 1913. For brevity’s sake, I do not take up the voluminous theoretical writings on cubism that have appeared since. For a recent view (emphasizing cubism’s semiological interrogation of the nature of the sign), with references to the broader literature, see FOSTER, H., KRAUSS, R., BOIS, Y., AND BUCHLOH B. (2004). *Art Since 1900*. New York: Thames & Hudson, 106-19, 691.

¹⁵ It was also suggested that cubism gave expression to recent developments in science and mathematics, including non-Euclidean geometries and the idea of a fourth dimension. See, for example, APOLLINAIRE, G. (1913). *Les Peintres Cubistes*. The English translation is excerpted in relevant part in CHIPP, H. (1968). *Theories of Modern Art: A Source Book by Artists and Critics*. Berkeley: University of California Press, 224.

1. *Symbols for Kinds of Evidence.* Each human assertion, offered to be credited, is conceived of as a testimonial fact; each fact of any other sort is a circumstantial fact.

Testimonial evidence affirmative (M testifies that defendant had the knife).

Testimonial evidence negative (M testifies that defendant did not have the knife).

Circumstantial evidence affirmative (knife was picked up near where defendant was; hence, defendant had it).

Circumstantial evidence negative (knife was found in deceased's hand; hence, defendant did not have it).

Same four kinds of evidence, when offered by the *defendant* in a case. (These are the same four kinds of evidence; it is merely convenient to note which party offers them).

Any fact judicially admitted, or noticed as a matter of general knowledge or inference, without evidence introduced.

Any fact presented to the *tribunal's own senses*, i. e. a coat shown, or a witness' assertion made in court on the stand. Everything actually evidenced must end in this, except when judicially noticed or judicially admitted.

Explanatory evidence; i. e. for circumstantial evidence, explaining away its effect (knife might have been dropped by a third person; for testimonial evidence, discrediting its trustworthiness (Witness was too excited to see who picked up the knife)).

Corroborative evidence; i. e. for circumstantial evidence, strengthening the inference, closing up other possible explanations (No third person was near the parties when the knife was found); for testimonial evidence, supporting it by closing up possibilities of testimonial error (Witness stood close by, was not excited, was disinterested spectator).

Same two kinds of evidence, when offered by the *defendant* in a case.

(1) *Provisional credit* given to *affirmatory* evidence, testimonial or circumstantial, is shown by adding an arrow-head.

Provisional credit given to *negative* evidence, testimonial or circumstantial, is shown by adding an arrow-head above a small cipher.

Particularly *strong credit* given to those kinds of evidence respectively is shown by doubling the arrow-head; this is usually applicable where several testimonies or circumstances concur upon the same fact.

(2) A small interrogation mark, placed alongside the connecting line, signifies *doubt* as to the probative effect of the evidence.

Similarly, for each kind of symbol, a small interrogation mark within it signifies a mental balance, an uncertainty; the alleged fact may or may not be a fact.

(3) A dot within the symbol of any kind of *alleged fact* signifies that we now *believe* it to be a fact. Particularly *strong belief* may be signified by two dots.

A small cipher within the symbol of any kind of alleged fact signifies that we now *disbelieve* it to be a fact. Particularly *strong disbelief* may be signified by two such ciphers; thus (oo).

(4) If a single supposed *explanatory* fact does, in our estimation after weighing it, detract from the force of the desired inference (in case of a witness, if it discredits his assertion), we signify this by an arrow-head pointing to the left, placed half way across the horizontal connecting line.

If a single *corroborative* fact is given effect in our estimation, we signify this by a short Roman letter X, placed across the connecting line.

Doubling the mark indicates particular strength in the effect, i. e. ←←, or ←←←.

Ultimately, when determining the total effect, in our estimation of all explanatory and corroborative facts upon the *net probative value* of the specific fact explained or corroborated, we place a short horizontal mark or small X, respectively, upon the upright connecting line of the latter fact.

Thus, for *net probative value*, several grades of probative effect may be symbolized: † signifies that the inference is a weak one; †† signifies that it has no force at all; ††† signifies that it is a strong one; †††† signifies that it is conclusive. When the supposed inference is a *negative* one, the same symbols are used, with the addition of the negatory symbol, i. e. † (Witness asserts that defendant had not a knife in his hand; witness's credit is supported by the fact that he is a friend of the deceased).

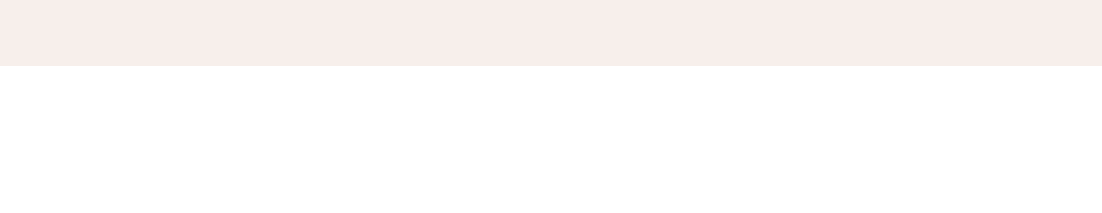

Figure 4. Glossary of Wigmore Chart Symbols
From *The Problem of Proof*

this gives the observer “a real simultaneous vision of all of its faces.”¹⁶ The “quest for a ‘simultaneity’ of the aspects of the object,” another writes, was “close to the heart of cubism.”¹⁷ Compare Wigmore on his chart method: “Many data, perhaps multifarious, are thrust upon us.” The task for the decision maker is “to avoid being misled (it may be) through attending only to some fragments of the mass of data. We must assume that a conclusion reached upon such a fragment only will be more or less untrustworthy.”¹⁸ The difficulty is that “those data have entered into the formation of our belief at *successive times*; hence a danger of omission or of inferior attention. Knowledge in the highest perfection would consist in the *simultaneous* possession of facts.”¹⁹ We see different sides of a case at different times; the challenge is somehow to see them all at the same time, to “enable all the data to be lifted into consciousness at once.”²⁰ To comprehend the whole matter and not just fragments, “it is necessary also to simplify it, to reduce it to its elements” – words that could have been Wigmore’s, though in fact they were written by the cubism theorist quoted above.²¹

¹⁶ LACOSTE, C. (1913). Sur le “cubisme” et la peinture. *Temps Present* (Paris, 2 April). Reproduced in English translation in *Cubism*, supra note 11, p. 120.

¹⁷ DELMARLE, F. (1914). Quelques note sur la simultanéité en peinture. *Poème et Drame* (Paris, 14 March). Reproduced in English translation in *Cubism*, supra note 11, p. 131.

¹⁸ The Problem of Proof, supra note 1, p. 79.

¹⁹ *Ibid.* (emphasis in original; internal quotation marks omitted).

²⁰ *Ibid.*, p. 82.

²¹ Sur le “cubisme” et la peinture, supra note 14, p. 121..

A related aim of both systems is to represent the processes of thought – to show how separate fragments of data are combined into a cognitive unit. For the cubists, one writer suggests in 1913, the aim is to get past the flow of mere sensory impressions in order to paint one’s mental conception of the object: “Therefore they no longer imitate the misleading appearances of vision, but the truer ones of the mind.”²² Compare Wigmore, for whom the purpose of his method is “*not* [to] show us what our belief *ought* to be,” but rather “to show only what our belief actually *is*, and *how* we have reached it.”²³ When seeing and hearing evidence, we test it in our consciousness and reach a conclusion. “And thus step by step we set down the separate units of actual belief, -- connecting, subsuming, and generalizing, until the subfinal grouping is reached; then dwelling in consciousness on that, until at last a belief (or disbelief) on the final fact evolves into our consciousness.”²⁴ The chart system tries to reproduce the assembly of sense data into an object of belief; it tries to show, as the cubists do, not just what we *see* but what we *know*. I really cannot do justice to the uncanny echoes between Wigmore’s manifesto for his system and the manifestoes for cubism that were being written by European art critics at the same moment. To read his work alongside theirs is to see how patently his article deserves to be treated as a document of high modernism.

²² RAYNAL, M. (1913). Qu-est-ce-que ... le Cubisme? *Comœdia Illustré* (Paris, 20 December). Reproduced in English translation in *Cubism*, supra note 11, p. 130.

²³ The Problem of Proof, supra note 1, p. 82 (*italics in original*).

²⁴ *Ibid.*, p. 83.

III

Some readers will object that I have committed a category mistake. Wigmore is creating not *pictures* but *diagrams*, bearing a greater resemblance – and, the objection would go, more properly compared – to electrical circuit charts or industrial flow charts than to cubist portraits. Yet are we sure about that? No one thinks of Wigmore’s work as having anything to do with the representation of women. But for that matter, no one thought that of cubist works either, at least not initially. During the Armory Show, a prize was offered to anyone who could actually find the alleged nude in one of the most notorious cubist works.²⁵ And who, even today, would know the subject matter of the *Standing Female Nude*, without either being told the title or being thoroughly acquainted with Picasso’s work? Yet there she is, once you look carefully: the female figure emerges unmistakably from Picasso’s tangled maze of lines, angles, and curves. Let us see whether we can also find her in, or between, the lines, angles and curves of the Wigmore system.

Having set forth the glossary of symbols in his system, Wigmore gives two examples of how evidence discrediting a trial witness should be diagrammed in hypothetical cases (figure 6). In both examples, the circle on top of the box on the upper right represents the testimony of the

²⁵ See *The Story of the Armory Show*, supra note 2, p. 136. The work in question was Duchamp’s *Nude Descending a Staircase*, one of the lightning rods of the show.

witness; the shapes to the left and below represent numbered items of evidence that discredit the testimony.²⁶ The symbols in Wigmore's system are presented as entirely arbitrary, with no necessary connection between signifier and signified, as Saussure might have put it. The shapes are not supposed to represent any information about a witness; they are simply said to designate certain formal qualities of the evidence (box = testimonial, circle = circumstantial, etc.). Look carefully at the images, however. In both, the refuted witness is represented by a venus symbol (♀), while the refuting evidence is represented as arrows – mars symbols (♂) in one of the figures – aimed roughly in the witness's direction. The witnesses in these hypothetical examples are not supposed to be women.²⁷ Yet the *concept* of discredited testimony takes the visual form of a female on a box; and the concept of evidence that exposes the truth takes the visual form of phalanx of sharp arrows pointed at her. This may or may not have been intentional. But it is no coincidence that untrustworthy evidence in this system is placed under the sign of the female.

Again and again in Wigmore's his voluminous work on evidence, women emerge as a menace to sound thinking and the search for truth, and a scientific approach to evidence becomes

²⁶ As Wigmore explains, the larger figure involves hypothetical testimony against a former employer. Items 19 and 19a in the figure represent the facts that the witness had been fired, and that a fired employee is likely to be biased; item 20 represents the demeanor of bias the witness showed on the stand. The smaller figure involves eyewitness testimony. Items 8, 9 and 10 are bits of information suggesting the witness could not have seen the incident clearly. See *The Problem of Proof*, supra note 1, pp. 87-88.

²⁷ In describing these examples Wigmore uses the male pronoun to refer to the discredited witness.

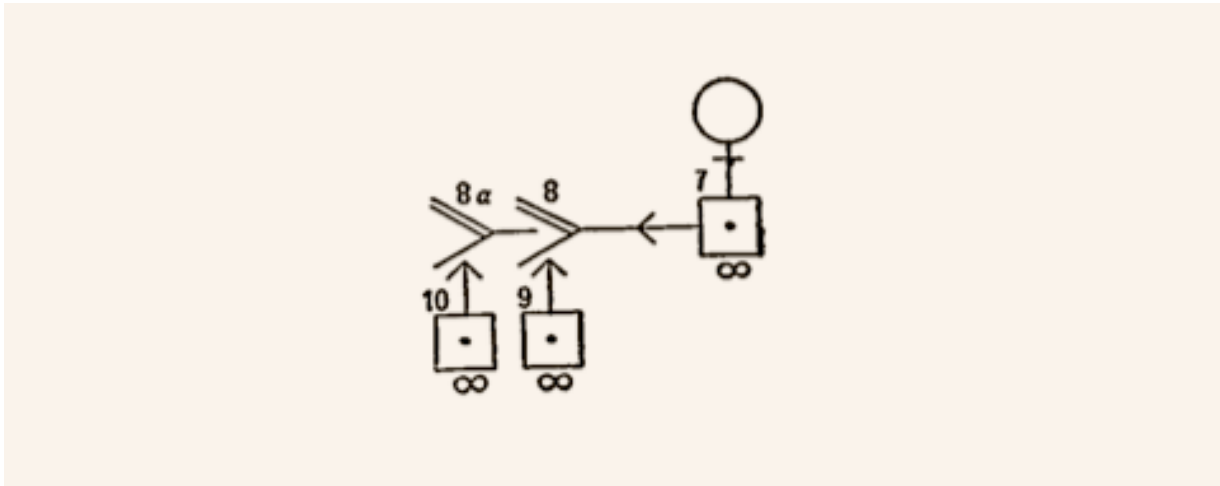
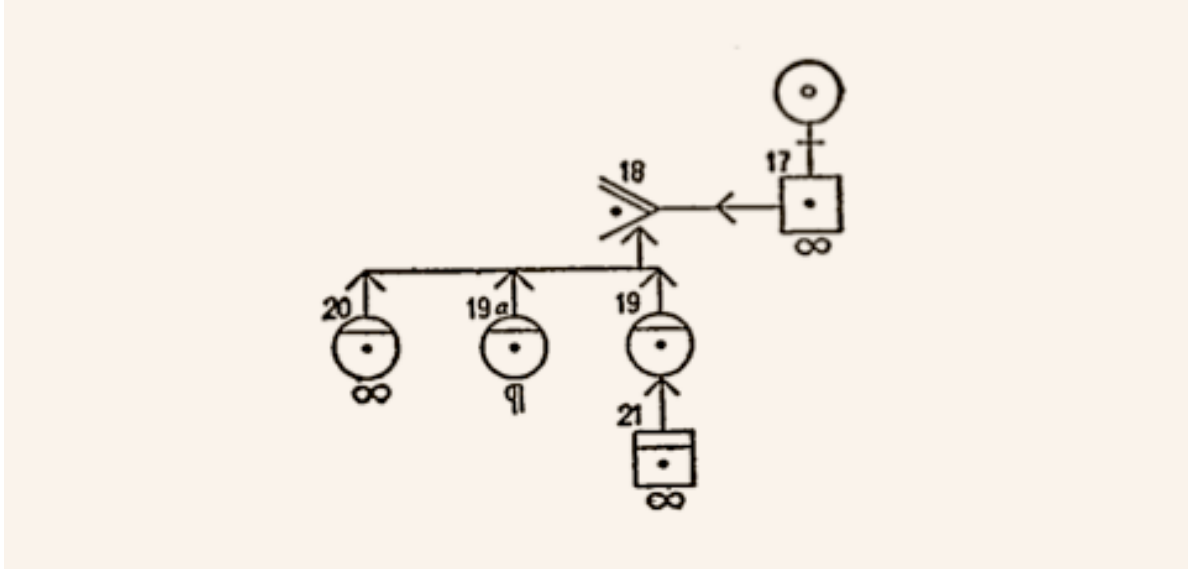

Figure 5. Wigmore, *Sample diagrams of evidence discrediting a witness*. 1913.
 From *The Problem of Proof*

synonymous with minimizing the influence of the irrationality and disorder associated with the female mind. The best-known instance of this is his position on the testimony of alleged rape victims, which is aptly summed up by the topic's placement in his Evidence Treatise. Here are two adjacent entries in the treatise's table of contents:

§ 200. Character of Complainant in Rape Charge, from Particular Acts of Unchastity.

§ 201. Disposition of an Animal, from its Behavior in Particular Instances.

Unchaste women, unruly animals. Sexual assault charges, in Wigmore's view, are often the fabrications of oversexed adventuresses who sleep with men and then turn around to cry rape. For this reason he vigorously advocates putting rape complainants' reputation and sexual history before the jury, and disapproves of rulings that limit the admission of such evidence.²⁸ But false rape charges are not only brought by women who asked for it; they are also brought by women who have masochistic fantasies they cannot distinguish from reality. This "unchaste (let us call it) mentality finds incidental but direct expression in the narration of imaginary sex-incidents of which the narrator is the heroine or the victim."²⁹ Hence his infamous proposal, purportedly backed with the authority of the latest psychological research, that no rape case should go to trial

²⁸ See WIGMORE, J. (1904). *A Treatise on the Anglo-American System of Evidence*. Boston: Little Brown. Volume I, p. 201.

²⁹ WIGMORE, J. (1940). *A Treatise on the Anglo-American System of Evidence*, Third Edition. Boston: Little Brown. Volume III, p. 459.

before a psychiatrist examines the supposed victim and determines that her story is not a wishful fantasy.³⁰

We learn more about the women's animalistic nature in Wigmore's *Principles of Judicial Proof*, the 1913 book whose publication accompanied the chart method article. The book contains some of Wigmore's own writings, but mostly consists of other authors' works that he offers as "illustrative" of the principles underlying the probative science he has called for in the chart article.³¹ The work of Hans Gross, the German criminologist whom I quoted in the epigraph, makes a frequent appearance. (Wigmore dedicates the book to Gross, "who has done more than any other man in modern times to encourage the application of science to judicial proof.")³² Wigmore reproduces an extensive passage from Gross to illustrate what Wigmore terms the "generic traits" of women.³³ Let us, the passage urges, confront honestly and unsentimentally the true nature of female psychology, in the spirit of scientific investigation. The facts are these: women feel rather than think; they intuit rather than reason; they gossip

³⁰ *Ibid.*, pp. 459-60. For a critical look at Wigmore's position, see Bienen, L. A Question of Credibility: John Henry Wigmore's Use of Scientific Authority in Section 924A of the Treatise on Evidence. *California Western Law Review*, **19**, 235.

³¹ *Principles of Judicial Proof*, supra note 1, p. 2.

³² *Ibid.*, dedication page.

³³ In the second edition of the book, Wigmore introduces this passage as demonstrating that "women are more apt to confuse what they really have observed with what they have imagined or wished to occur; and [relative to men] are apt to fall below in candor and honesty." WIGMORE, J. (1931). *The Principles of Judicial Proof, or The Process of Proof, As Given By Logic, Psychology and General Experience and Illustrated in Judicial Trials*. Second Edition. Boston: Little Brown, p. 292.

endlessly never get to the point; they perceive the world in terms of concrete objects and personalities, and cannot think logically, analytically, or conceptually; and “they have no real knowledge of justice.”³⁴ Most importantly for purposes of the science of proof, the fairer sex has serious trouble telling the truth. “Dishonesty,” we learn, “is a specially feminine characteristic; in men it occurs only when they are effeminate. Real manliness and dishonesty are concepts which cannot be united.” You can seldom get a straight answer out of a woman, and if you do it is probably the opposite of what she means:³⁵

But even her simplest affirmation or denial is not honest. Her ‘no’ is not definite; e.g., her “no” to a man’s demands.... So Schopenhauer agrees: “Nature has given women only one means of protection and defense – hypocrisy: this is congenital with them, and the use of it is as natural as the animal’s use of its claws.

No means yes; and watch out for her claws. This is the female, which the many “science of proof” must face down and bring to heel.

And here is a passage from a book on trial advocacy Wigmore offers to illustrate the principles of the “testimonial process”: The ferocious beast rears her head again:³⁶

When a witness comes into the box with what is commonly called a “knowing” look, and with a determined pose of the head, as though he would say, “Now, then Mr. Counselor,

³⁴ *Principles of Judicial Proof*, supra note 1., pp. 340-42. This passage is presented as an excerpt from GROSS, H. (1911). *Criminal Psychology*.

³⁵ *Ibid.*, p. 343 (ellipses in original).

³⁶ *Ibid.*, p. 530 (ellipses added). This passage is presented as a quotation from HARRIS, R. (1892). *Hints on Advocacy*.

I'm your man, tackle me," you may be sure you have a Flippant and masterful being to deal with.... But although I have used the masculine pronoun, this witness is very often a female. ...

You will always approach her as if she were a wild animal ready to tear you if she could get near enough.

Talk about fauvism: the recurrent association of women with wild animals is remarkable.³⁷

Consider, finally, the two sample full-scale charts Wigmore includes in his article, which I reproduced earlier. One (figure 1) is the author's diagrammatic representation of the evidence from a 1901 Massachusetts case; the other (figure 3) refers to an 1882 Virginia case.³⁸ Without going into their details, I think it is worth observing what kinds of case these charts are pictures of. Here, in brief, are the facts of the Massachusetts case: a man sought to prevent the defendant's marriage to a woman, apparently out of jealousy; later his decapitated body was found at the defendant's workplace, the defendant was convicted of his murder, and the conviction upheld on appeal. Here are the facts of the Virginia case: a man died of poisoning after drinking whiskey delivered by the defendant, who was charged with his murder; his conviction was overturned by the state's high court, which suggested he had been framed by the victim's wife, who was having an affair and "had been supplied by her paramour with strychnine to administer to her husband." Notice the pattern. In one case a woman has used her charms on

³⁷ The Fauvist painters get their name from the French word for wild beasts.

³⁸ The cases in question are *Commonwealth v. Umilian*, 171 Mass. 582 (1901), and *Hatchett v. Commonwealth*, 76 Va. 1026 (1882). For the opinions, evidence lists, and charts, see *The Problem of Proof*, supra note 1, pp. 91-103.

two men, one of whom is decapitated as a result. In the other, an unfaithful wife kills her husband and lets an innocent man take the rap. Female promiscuity and double-dealing leading to death, destruction of innocent men's lives, and male decapitation: these are the themes encoded in the innocuous little shapes in Wigmore's drawings, and the animalistic dangers against which his geometric apparatus is designed to provide some measure of protection.

In pointing out the irrational, misogynistic overtones of his system, my purpose has not to pick on Wigmore, whose attitudes toward women were no worse than average for his era. In some respects they were better; he was more respectful of women law students than many of his contemporaries.³⁹ My point is simply that the "unsafe mental processes" that his chart method article warned against tend, in the scheme of his writings, to be associated with the seductions and duplicities of sexually licentious women. Let the courts beware of the woman of unchaste body or mind who lies on the witness stand and ruins a man's life; in the same way, let the science of proof be on guard against "unguided, and therefore unsafe" patterns of thought that would ruin its claim to be a true science. These projects are mirror images of each other in the rhetorical, conceptual and psychic universes of the chart method. Loose thinking is the

³⁹ His biographer reports that Wigmore agreed on one occasion to serve as master of ceremonies for a joint social event for law students at Northwestern and another law school. Told by a student that she was not invited because it was a stag event, Wigmore announced that he would not participate if Northwestern's women students were excluded. See ROALFE, W. (1977). *John Henry Wigmore: Scholar and Reformer*. Evanston: Northwestern University Press, p. 67.

counterpart of a loose woman; clean analysis is the sign of female probity and the containment of sexuality; a systematic diagram the index of a legal system that has not permitted itself to be unmanned by female teeth and claws. The implicit psychic function being served is hinted at, I think, by the title of another publication from 1913: *Totem and Taboo*.⁴⁰

Viewing it in this way, we can see that the Wigmore system, novel as it is in some respects, has a long lineage in western graphic design. Consider, to take a single example, *Draftsman Drawing a Reclining Nude*, whose 1538 treatise on geometric drawing and its applications (in which the woodcut appears) is an important precursor to modern analytical chart systems.

⁴⁰ FREUD, S. (1913). *Totem and Taboo*. The Standard Edition of the Complete Psychological Works of Sigmund Freud, vol. XIII (Strachey, ed., 1955).

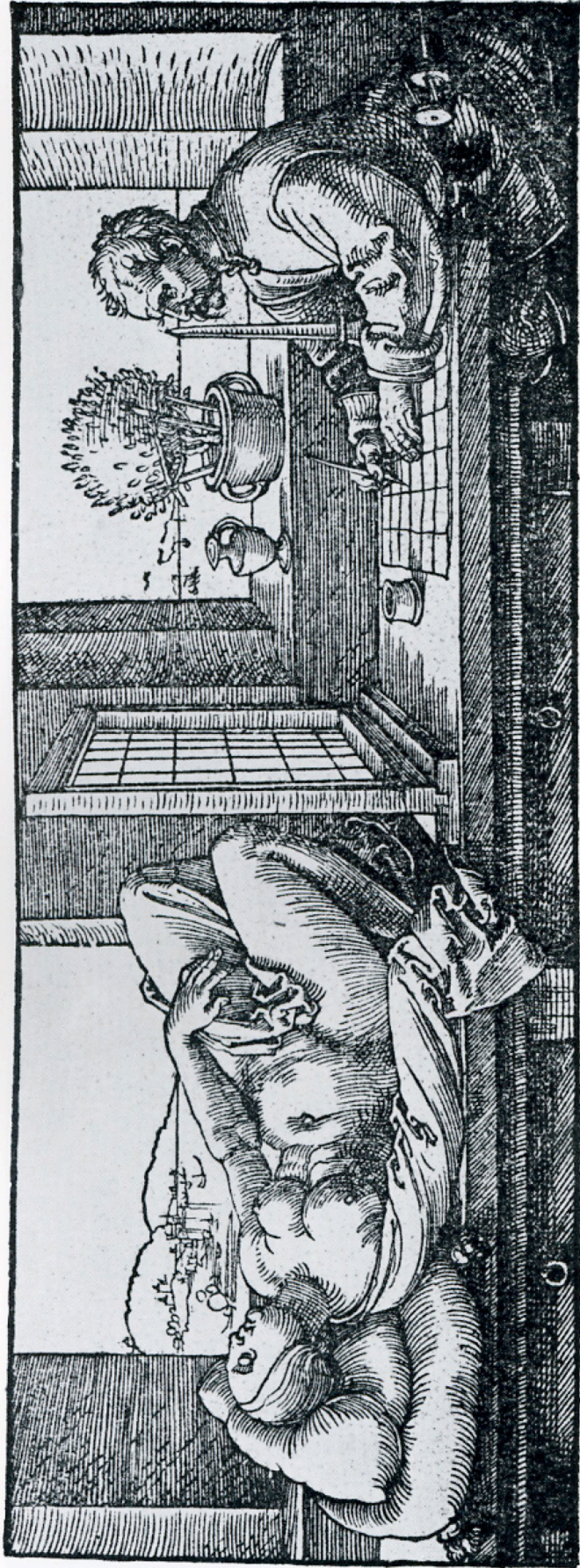

Figure 5. Dürer, *Draftsman Drawing a Reclining Nude*. c. 1525.
Houghton Library, Harvard University

In Durer's image, the man uses a reticulated net and a viewing rod to accurately register the proportions of his subject on an oblong sheet of paper. As Lynda Nead and others have pointed out, the picture dramatizes the transformation of disorderly nature, figured as a scantily clad, voluptuous female, into ordered knowledge, figured as a disciplined, attentive male accompanied by vertical instruments and a carefully manicured tree.⁴¹ The figure sets in opposition culture to nature, abstraction to physicality, knowledge to sexuality, male to female. Notice the positioning of the woman's hand, and the air of anxiety hanging over the draftsman. The screen grid with its protects him from the feminine and enables him to impose order on it. Geometric clarity and scientific knowledge, in this picture, go hand in hand with the control of women and the containment of female sexuality. The draftsman who would tame the beast must keep his lines straight, his angles right, and his drawing implement sharp. Hence the instructions – from Wigmore – for good diagram drawing:

Use an oblong sheet of unruled paper. ...

Use right-angled continued lines. ...

⁴¹ See NEAD, L. (1992). *The Female Nude: Art, Obscenity, and Sexuality*. New York: Routledge, pp. 2, 11. For similar analyses of the image, see RUSSELL, H.D. (1990). *Eva/Ave: Woman in Baroque and Renaissance Prints*. Washington, D.C.: National Gallery of Art, pp. 21-23; FREEDMAN, B. (1991). *Staging the Gaze: Postmodernism, Psychoanalysis, and Shakespearean Comedy*. Ithaca, N.Y.: Cornell University Press, pp. 1-2. On the semiotics of representation of the female body in western art more generally, see the essays collected in *Reclaiming Female Agency: Feminist Art History After Postmodernism* (Broude & Garrard eds.). Berkeley: University of California Press, 2005; *The Expanding Discourse: Feminism and Art History* (N. Broude & M. Garrard eds.). New York: Harper Collins, 1992; *The Female Body in Western Culture: Contemporary Perspectives* (S. Suleiman ed.). Cambridge, Mass.: Harvard University Press, 1986.

Use a sharpened lead pencil.⁴²

The Durer woodcut helps us understand some of the significance of these words. As does the work of Picasso, so much of which, like the woodcut and the Wigmore chart, is devoted to finding new formal techniques for disassembling the female body.

IV

I do not want to be misunderstood as saying that analytical diagrams of this type (or scientific approaches to evidence more generally) are inherently associated with the cluster of anxieties I have identified here. Any such generalization would be completely out of keeping with premise of this paper, which is that identifying the meaning(s) of an image requires close attention to its specific context, which in this case means the written apparatus of which it is a part. To date, connoisseurs of the Wigmore system have, I think, been overly taken with its formal properties, treating it as the purely cognitive system its author presented it as, ignoring the full range of meanings embedded in its strange figures.

In this respect they may have traced a path similar to the one Picasso scholars have followed when interpreting his epochal *Les Femmes d'Alger* (figure 7).⁴³ For decades,

⁴² The Problem of Proof, supra note 1, pp. 88-89.

⁴³ By way of defending the title for this article, I note that while Northwestern's law school is in Chicago, Wigmore lived in Evanston, where the rest of the university is located. See *John Henry Wigmore: Scholar and Reformer*, supra note 34, at 71.



Figure 7. Pablo Picasso, *Les Femmes d'Alger (O. J. R. Version O)*. 1911-12.
Museum of Modern Art, New York.

critical assessments of this painting focused almost entirely on its formal pictorial innovations –

the flattening and splintering of space, the proto-cubist reduction of the figures, the appropriation of Egyptian and African tribal art, the utter sabotaging of Renaissance compositional conventions. Only since the 1970s has a “revisionist” critical literature emphasized that this painting is, after all, a picture of prostitutes, and that its sharp edges and menacing figures enact a psychosexual drama blending fears of women, death, and castration.⁴⁴ A revisionist understanding of Wigmore’s contribution to modernism might, as I’ve suggested, proceed along roughly similar lines. If my reading punctures some of his system’s pretensions, it also puts him in distinguished company. I hope it serves as a reminder that analytical charts are *pictures*, whatever else they may be. And that as students of visual evidence, we can never learn to look too closely at the pictures we are seeing.

⁴⁴ A sample of recent scholarship, plus an overview of the history of the work’s critical reception, is contained in the anthology *Picasso’s Les Femmes d’Alger (O. J. R. 1909)* (C. Green ed.). Cambridge: Cambridge University Press, 2001. The pivotal revisionist work examining the painting’s erotic dimensions was Leo Steinberg’s essay *The Philosophical Brothel*, in *Art News*, vol. 71 nos. 5-6 (Sept. and Oct. 1971), reprinted in *October*, vol. 44 (Spring 1988), pp. 4-74. See also *Les Femmes d’Alger (O. J. R. 1909)*, *Studies in Modern Art 3* (Rubin, Seckel and Cousins eds.). New York: Museum of Modern Art, 1994; CHAVE, A. (1994). New Encounters with *Les Femmes d’Alger (O. J. R. 1909)*. *Art Bulletin*, 76, 597.

