



# High-accuracy continuous airborne measurements of greenhouse gases (CO<sub>2</sub> and CH<sub>4</sub>) using the cavity ring-down spectroscopy (CRDS) technique

The Harvard community has made this article openly available. [Please share](#) how this access benefits you. Your story matters

Citation	Chen, H., J. Winderlich, C. Gerbig, A. Hofer, C. W. Rella, E. R. Crosson, A. D. Van Pelt, et al. 2010. "High-Accuracy Continuous Airborne Measurements of Greenhouse Gases (CO <sub>2</sub> and CH <sub>4</sub> ) Using the Cavity Ring-down Spectroscopy (CRDS) Technique." <i>Atmos. Meas. Tech.</i> 3, no. 2: 375–386. doi:10.5194/amt-3-375-2010
Published Version	doi:10.5194/amt-3-375-2010
Citable link	<a href="http://nrs.harvard.edu/urn-3:HUL.InstRepos:30760597">http://nrs.harvard.edu/urn-3:HUL.InstRepos:30760597</a>
Terms of Use	This article was downloaded from Harvard University's DASH repository, and is made available under the terms and conditions applicable to Other Posted Material, as set forth at <a href="http://nrs.harvard.edu/urn-3:HUL.InstRepos:dash.current.terms-of-use#LAA">http://nrs.harvard.edu/urn-3:HUL.InstRepos:dash.current.terms-of-use#LAA</a>

# High-accuracy continuous airborne measurements of greenhouse gases (CO<sub>2</sub> and CH<sub>4</sub>) using the cavity ring-down spectroscopy (CRDS) technique

H. Chen<sup>1</sup>, J. Winderlich<sup>1</sup>, C. Gerbig<sup>1</sup>, A. Hofer<sup>1</sup>, C. W. Rella<sup>2</sup>, E. R. Crosson<sup>2</sup>, A. D. Van Pelt<sup>2</sup>, J. Steinbach<sup>1</sup>, O. Kolle<sup>1</sup>, V. Beck<sup>1</sup>, B. C. Daube<sup>3</sup>, E. W. Gottlieb<sup>3</sup>, V. Y. Chow<sup>3</sup>, G. W. Santoni<sup>3</sup>, and S. C. Wofsy<sup>3</sup>

<sup>1</sup>Max Planck Institute for Biogeochemistry, 07745 Jena, Germany

<sup>2</sup>Picarro, Inc., Sunnyvale, CA 94085, USA

<sup>3</sup>Department of Earth and Planetary Sciences and the Division of Engineering and Applied Sciences, Harvard University, Cambridge, Massachusetts, USA

Received: 19 November 2009 – Published in Atmos. Meas. Tech. Discuss.: 4 December 2009

Revised: 3 March 2010 – Accepted: 17 March 2010 – Published: 24 March 2010

**Abstract.** High-accuracy continuous measurements of greenhouse gases (CO<sub>2</sub> and CH<sub>4</sub>) during the BARCA (Balanço Atmosférico Regional de Carbono na Amazônia) phase B campaign in Brazil in May 2009 were accomplished using a newly available analyzer based on the cavity ring-down spectroscopy (CRDS) technique. This analyzer was flown without a drying system or any in-flight calibration gases. Water vapor corrections associated with dilution and pressure-broadening effects for CO<sub>2</sub> and CH<sub>4</sub> were derived from laboratory experiments employing measurements of water vapor by the CRDS analyzer. Before the campaign, the stability of the analyzer was assessed by laboratory tests under simulated flight conditions. During the campaign, a comparison of CO<sub>2</sub> measurements between the CRDS analyzer and a nondispersive infrared (NDIR) analyzer on board the same aircraft showed a mean difference of  $0.22 \pm 0.09$  ppm for all flights over the Amazon rain forest. At the end of the campaign, CO<sub>2</sub> concentrations of the synthetic calibration gases used by the NDIR analyzer were determined by the CRDS analyzer. After correcting for the isotope and the pressure-broadening effects that resulted from changes of the composition of synthetic vs. ambient air, and applying those concentrations as calibrated values of the calibration gases to reprocess the CO<sub>2</sub> measurements made by the NDIR, the mean difference between the CRDS and the NDIR during

BARCA was reduced to  $0.05 \pm 0.09$  ppm, with the mean standard deviation of  $0.23 \pm 0.05$  ppm. The results clearly show that the CRDS is sufficiently stable to be used in flight without drying the air or calibrating in flight and the water corrections are fully adequate for high-accuracy continuous airborne measurements of CO<sub>2</sub> and CH<sub>4</sub>.

## 1 Introduction

Efforts to measure the concentration of carbon dioxide (CO<sub>2</sub>) in the atmosphere to obtain the temporal and geographic distribution of atmospheric CO<sub>2</sub> have been made since the 19th century (Callendar, 1940). Measurements of CO<sub>2</sub> play an important role in understanding the global carbon cycle and its contribution to the global warming (Bischof, 1962; Keeling et al., 1968; Tans et al., 1996; Heimann, 2009). In recent years, methane (CH<sub>4</sub>) has received increasing attention as the second most important anthropogenic greenhouse gas after CO<sub>2</sub> because of the high uncertainty of its sinks and sources (Houweling et al., 2006; Keppler et al., 2006; Miller et al., 2007; Frankenberg et al., 2008). Among the wide variety of platforms (from ground-based stations, towers, ships, aircraft and balloons to satellites) on which CO<sub>2</sub> and CH<sub>4</sub> measurements can be acquired, aircraft measurements are essential for observations in the free troposphere and lower stratosphere covering regional to continental scales. However, obtaining measurements on board aircraft is challenging due to



Correspondence to: H. Chen  
(hchen@bgc-jena.mpg.de)

the difficulty of ensuring high accuracy under severe conditions of changing pressure and temperature as well as mechanical stress due to shock and vibration. Therefore, initially the primary method of acquiring airborne CO<sub>2</sub> and CH<sub>4</sub> measurements was to collect air samples in flasks or other containers during a flight and analyze the air later in the laboratory (Keeling et al., 1968). Even nowadays, flask measurements are still a reliable way for airborne measurements to determine concentrations of species of interest in the atmosphere. Although very reliable, flask measurements have limitations which restrict its ability to capture temporal and spatial variability information, especially for observations within the boundary layer. During the last 30 years, high-accuracy in situ airborne CO<sub>2</sub> measurements (mainly using the NDIR technique) have been carried out both in aircraft campaigns and in routine flights (Boering et al., 1994; Anderson et al., 1996; Daube et al., 2002; Machida et al., 2002; Shashkov et al., 2007; Machida et al., 2008). However, only in recent years has high-accuracy in situ CH<sub>4</sub> instrumentation become available for airborne measurements (Jimenez et al., 2005).

In this paper, we present a high-accuracy analyzer using the wavelength-scanned cavity ring-down spectroscopy (CRDS) technique for continuous measurements of CO<sub>2</sub> and CH<sub>4</sub> with minimum maintenance in the field during the BARCA phase B campaign in Brazil in May 2009. Unlike all previous techniques, this analyzer is able to monitor atmospheric CO<sub>2</sub> and CH<sub>4</sub> of high accuracy without the need to dry the sample air or to employ in-flight calibrations. It was necessary to perform in-flight calibrations and careful air drying techniques in all previous in situ airborne measurements of CO<sub>2</sub> and CH<sub>4</sub> within the troposphere in order to guarantee measurement accuracy. The need for calibration was driven by the lack of stability of the analyzers within a flight period under changing pressure and temperature conditions, while the reason for drying the air was the difficulty of measuring water vapor precisely. The high performance and low maintenance of the CRDS analyzer has made it the choice as the analyzer for measurements of greenhouse gases on board a commercial airliner within a European Union project of In-service Aircraft for a Global Observing System (IAGOS).

This paper describes techniques and presents results of laboratory experiments necessary to validate and verify CRDS analyzer performance before deployment. The measurement principle used in this analyzer is introduced in Sect. 2. Then the laboratory experiments used to derive the water correction functions for CO<sub>2</sub> and CH<sub>4</sub> and to assess the performance under simulated flight conditions are described in Sects. 3 and 4, respectively. In Sect. 5 we compare airborne CO<sub>2</sub> measurements of the CRDS analyzer with independent measurements made by an NDIR analyzer. Section 6 discusses a cross-calibration for the two analyzers and Sect. 7 concludes the paper.

## 2 The CRDS analyzer

In the CRDS technique, the gas sample is analyzed in a high-finesse optical cavity; the optical absorbance of the sample is determined by the light dissipation rate in the optical cavity, thus typically providing parts-per-billion mixing ratio or isotopic ratio measurements of a particular gas species of interest which are in good approximation independent of the intensity fluctuations of the excitation light source. This technique has been successfully implemented in a ground-based greenhouse gas analyzer (Crosson, 2008). The analyzer (Picarro Inc., CA, USA, model G1301) employs two lasers, a high-precision wavelength monitor, a high finesse optical cavity with three high-reflectivity mirrors (>99.995%), a photodetector and a computer. During the measurements, light at a specific wavelength from a laser is injected into the cavity through a partially reflecting mirror. The light intensity then builds up over time and is monitored through a second partially reflecting mirror using a photodetector located outside the cavity. The “ring-down” measurement is made by rapidly turning off the laser and measuring the time constant of the light intensity as it exponentially decays. The lasers are tuned to scan over the individual spectral lines of <sup>12</sup>C<sup>16</sup>O<sub>2</sub> at the wavelength of 1603 nm, <sup>12</sup>CH<sub>4</sub> and H<sub>2</sub><sup>16</sup>O at the wavelength of 1651 nm producing a high resolution spectrum of each. Fits to each of these high-resolution absorption spectra are then obtained, from which the constituent quantities of the gas sample are determined. The temperature and pressure of the gas sample are tightly controlled at 45 °C and 140 Torr in the G1301 (variations of less than 20 mK and 0.1 Torr, respectively), leading to highly stable spectroscopic features. The measurement speed is around 5 s (0.2 Hz). The flight analyzer (Picarro Inc., CA, USA, model G1301-m) was developed on the basis of the previous model, G1301. Because the performance requirements of the flight analyzer and environmental conditions seen in flight are considerably more difficult to meet than are those for the standard G1301 product, significant modifications were undertaken which resulted in new hardware, electronics, and software. These changes included a) adding an ambient pressure sensor and applying an ambient pressure correction to the high-precision wavelength monitor to ensure wavelength targets are met correctly under quickly changing ambient pressure; b) introducing three additional temperature sensors strategically located on the CRDS cavity and new firmware to enable correct operation of the analyzer’s sample, pressure and temperature control systems; c) replacing the computer hard drive with a solid-state drive; d) increasing the data acquisition rate of the analyzer from 0.2 Hz to 0.5 Hz.

### 3 Laboratory experiments to derive water correction functions

Atmospheric water vapor varies over small temporal and spatial scales in the magnitude of a few ppm in the stratosphere to a few percents in the troposphere. Mixing ratios of CO<sub>2</sub> and CH<sub>4</sub> are significantly affected by variations of water vapor, when using wet air mixing ratios (number of moles of the species divided by the number of moles in wet air). This impact of variations of water vapor on the mixing ratios of CO<sub>2</sub> and CH<sub>4</sub> is called dilution effect. To avoid this dilution effect, CO<sub>2</sub> and CH<sub>4</sub> mixing ratios are always reported as dry mole fractions. In order to ensure that the accuracy of measurements of CO<sub>2</sub> mixing ratios in dry air is better than 0.1 μmol/mol (ppm) according to the WMO recommendation (WMO, 2003) at the ambient level of ~400 ppm, the mixing ratio of water vapor in the sample air is either required to be removed to a level below 250 ppm or simultaneously measured at a precision of below 250 ppm to correct the water vapor dilution effect. The dilution effect for CH<sub>4</sub> is less significant than for CO<sub>2</sub>: to achieve the WMO recommended accuracy target of 2 ppb for CH<sub>4</sub> mixing ratio measurements at the ambient level of ~2000 ppb, the corresponding requirement for water vapor mixing ratios is only below 1000 ppm.

Furthermore, measurements using spectroscopy techniques are sensitive to water vapor variability via changes in degree of pressure broadening of the spectroscopic lines used to measure the mixing ratios of CO<sub>2</sub> and CH<sub>4</sub>. Here, the term “pressure broadening” includes two effects: the Lorentzian line broadening caused by collisions between the analyte molecules, and Dicke line narrowing of the Gaussian distribution of kinetic energy caused by energy-exchanging collisions. Both of these effects are proportional to pressure, but occur with different magnitudes depending both on the choice of ro-vibrational absorption line of the analyte molecule as well as the composition of the background gas matrix; i.e. different background gas mixtures will lead to different broadening coefficients. In ambient air, the concentration of water vapor varies enough to cause measurable changes in these line-broadening parameters of the target analyte absorption lines. Other gases in the ambient atmosphere, like oxygen, nitrogen, argon, carbon dioxide, methane, and other trace constituents, do not vary enough (<~100 ppm) to cause measurable line broadening effects (though, in synthetic gas standards, the inert gases can present a problem, as discussed below).

These line-broadening effects do not affect the total area of the absorption line, but they do affect the peak height. The CRDS analyzer uses the absorption peak heights to calculate concentration; the peak height is used because of the higher noise present in the peak area measurement, due to systematic noise in the absorption baseline as well as noise in the measurement of the wavelength. Because the peak height is not constant for a given mixing ratio, variability in the line

broadening thus leads to systematic errors in the reported mixing ratios. For the carbon dioxide and methane lines employed in the CRDS analyzer, the line-broadening effects, if not corrected, would lead to systematic errors of about 40% of the dilution effects.

In addition, the measurement of water vapor mixing ratio by the CRDS analyzer is also subject to these line-broadening effects. In this case, it is self-broadening (and Dicke line narrowing) of the water vapor absorption line by water vapor itself, which leads to variations in the absorption line shape and thus a nonlinearity of the reported water vapor concentration as a function of the true water vapor concentration.

Finally, the absolute calibration of the water vapor reading is subject to significant (~1%) uncertainty, due to the difficulty in generating and delivering a known water vapor sample with high accuracy to the instrument.

If considered on an individual basis, each of these uncertainties (dilution, line broadening, water vapor nonlinearity, and absolute water vapor calibration) could result in a substantial overall uncertainty in the dry gas mixing ratios for carbon dioxide and methane. However, we can take advantage of the fact that the CRDS analyzer provides highly *precise* readings of all three gases. By performing careful experiments, we can derive empirical expressions that directly relate the actual dry gas mixing ratios for carbon dioxide and methane to the *measured* water vapor readings. All the effects discussed above are then combined into a single expression which does not rely on careful understanding of each effect considered individually. In the section below, we assess whether, by using such an expression, the water vapor measurements provided by the CRDS analyzer are adequate for correcting the dilution and the pressure-broadening effects for carbon dioxide and methane.

#### 3.1 Experiments

In order to derive water correction functions for CO<sub>2</sub> and CH<sub>4</sub>, a series of experiments were carried out using the setup given in Fig. 1. Gas from a high-pressure tank containing ambient air was supplied to a humidifier or dew point generator (Li-Cor, Inc., Lincoln, NE, USA, model LI-610) after the gas pressure was reduced to a level slightly above the ambient pressure using a combination of a high pressure regulator (Scott Specialty Gases, Plumsteadville, PA, USA, model 51-14D) and a needle valve. The ambient air tank was prepared in Max Planck Institute for Biogeochemistry in Jena (MPI-Jena), Germany, using dried and compressed air from outside the building with CO<sub>2</sub> mixing ratios of ~400 ppm. The LI-610 humidifier could generate a moist air stream with a known setting dew point ranging from 0 to 50 °C. After the gas was humidified, it was split into two paths, one with and the other without a chemical dryer (magnesium perchlorate). Carefully balancing the flow and pressure ensures that there was no change in pressure in the chemical dryer while

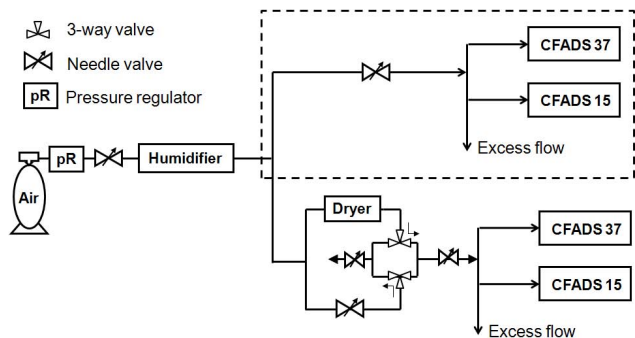
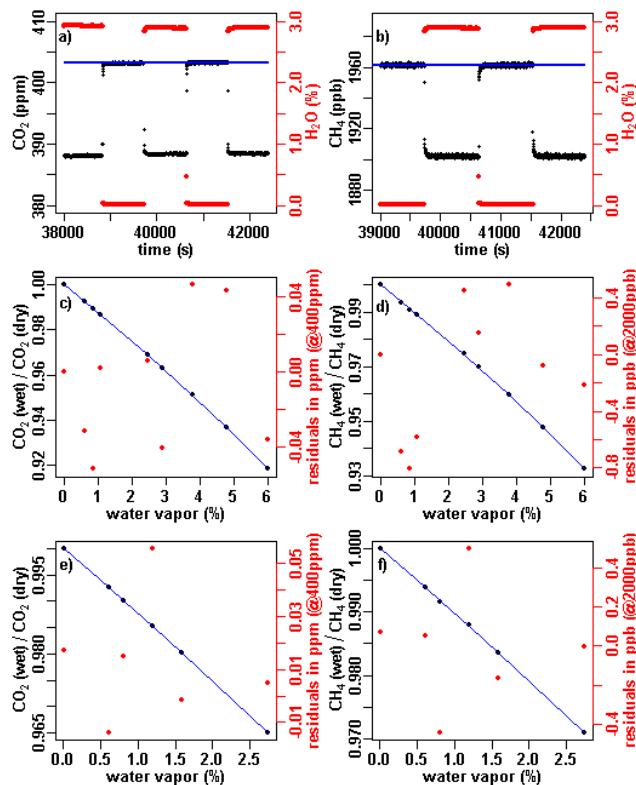

**Fig. 1.** Schematic of the setup for experiments to derive water vapor correction functions (experiments were done separately to the two CRDS analyzers, i.e. CFADS 37 and CFADS 15 although they could be tested at one time) and correlate water vapor measurements of two individual CRDS analyzers (see inside the dashed lines).

switching. This avoided the influence of magnesium perchlorate under conditions of changing pressure on  $\text{CO}_2$  mixing ratios (Levin et al., 2002). A crossover valve that was made of two 3-way valves was located downstream of the dryer and was controlled by a data logger (Campbell Scientific, Inc., Logan, UT, USA, model CR23X) that selected dry or wet air to flow through the CRDS analyzer.

Two CRDS analyzers were tested using this setup. The experiments for the flight version G1301-m were performed in a temperature-controlled room ( $\sim 38^\circ\text{C}$ ) to prevent water vapor from condensing on the walls of tubing before flowing into the analyzer. The humidifier was sequentially set by the above described data logger to dew points  $0^\circ\text{C}$ ,  $5^\circ\text{C}$ ,  $10^\circ\text{C}$ ,  $15^\circ\text{C}$ ,  $20^\circ\text{C}$ ,  $25^\circ\text{C}$ ,  $30^\circ\text{C}$  and  $35^\circ\text{C}$ , corresponding to reported water vapor mixing ratios from 0.6% to 6%. The experiments were interrupted several times when the chemical dryer had to be changed. The objective for performing the experiments under above room temperature is to supply water vapor of high mixing ratios to the CRDS analyzer so that we could better describe the nonlinearity of water vapor correction curves. If inlet losses of water vapor occurred under flight conditions, these would not have caused a problem for water corrections, because the CRDS analyzer measures the water vapor mixing ratios of the air in the cavity, which are the exact concentrations that should be used for correcting water vapor effects for  $\text{CO}_2$  and  $\text{CH}_4$ . However, condensation is not expected under flight conditions, since due to the rearward facing inlet, the pressure in the inlet tube is lower than ambient, which reduces the dew point of the sample air.

The  $\text{CO}_2$  mixing ratio of the gas downstream of the humidifier often drifted linearly or exponentially due to solubility of  $\text{CO}_2$  in water in the humidifier. The drifts were removed before calculating the mixing ratio for both dry and wet cycles. The magnitude of the drift for  $\text{CO}_2$  is about several tenths of a ppm within an hour period. The  $\text{CH}_4$  mixing ratio was calculated in the same way as the  $\text{CO}_2$



**Fig. 2.** (a–b) Examples of the responses of  $\text{CO}_2$  and  $\text{CH}_4$  while switching between wet and dry air (see  $\text{H}_2\text{O}$  on the right axis), and linear drift corrections (blue lines). On the time axis, the values are the seconds that have lapsed since the beginning of the day when the experiment was carried out (c–d) Quadratic fits of  $\text{CO}_{2\text{wet}}/\text{CO}_{2\text{dry}}$  and  $\text{CH}_{4\text{wet}}/\text{CH}_{4\text{dry}}$  vs.  $\text{H}_2\text{O}$  mixing ratios. (e–f) Results from similar experiments performed with CFADS 15, with the curve showing the fit from experiments using CFADS 37. The red dots in (a–d) are residuals of corresponding fits and are read on the axis to the right. Note that (a–d) are results from experiments performed with CFADS 37 and (e–f) with CFADS 15.

mixing ratio, however, the drift of  $\text{CH}_4$  concentration was insignificant since solubility of  $\text{CH}_4$  in water is poor (see Fig. 2a–b). The precision of the measurement of the water vapor mixing ratio of the CRDS analyzer is 23 ppm ( $1\sigma$ ) at reported 4%  $\text{H}_2\text{O}$  level (the maximum water vapor level during the campaign, excluding the cases of flying through cloud or rain), which is precise enough for correcting the dilution effect. In fact, both the dilution and the pressure-broadening effects can be compensated by the reported  $\text{H}_2\text{O}$  mixing ratios. The effects of water vapor dilution as well as of pressure broadening for  $\text{CO}_2$  and  $\text{CH}_4$  can be represented by quadratic fits,  $\text{CO}_{2\text{wet}}/\text{CO}_{2\text{dry}}=1+a\times\text{H}_2\text{O}+b\times\text{H}_2\text{O}^2$  and  $\text{CH}_{4\text{wet}}/\text{CH}_{4\text{dry}}=1+c\times\text{H}_2\text{O}+d\times\text{H}_2\text{O}^2$ ,  $a=-0.012000\%^{-1}$ ,  $b=-0.000267\%^{-2}$ ,  $c=-0.009823\%^{-1}$ ,  $d=-0.000239\%^{-2}$  (see Fig. 2c–d). The residual errors of the fits were below 0.05 ppm for  $\text{CO}_2$  and below 0.8 ppb for  $\text{CH}_4$ .

### 3.2 Transferability of the water correction functions

It is important to assess if the coefficients of the water correction functions derived from the laboratory experiment can be regarded as constants or whether a recalibration of these parameters via laboratory experiment is required. Rather than repeating the experiments at different times, e.g. after a year, we decided to repeat the experiment with a different analyzer.

We compared water correction functions of the flight CRDS analyzer (model G1301-m, serial designation CFADS 37) with those of one ground-based CRDS analyzer (model G1301, serial designation CFADS 15). We use CFADS 37 and CFADS 15 throughout the subsequent text to differentiate the two CRDS analyzers.

Experiments were performed for CFADS 15 using the same setup as for CFADS 37 (see Fig. 1); however, the reported water vapor mixing ratios ranged from 0.61% to 2.76%. To correlate the water vapor measurement of CFADS 15 with CFADS 37, step-changing wet air (from 1.09% to 2.11%) from the humidifier described above was provided to the two analyzers simultaneously (see Fig. 1). The water vapor measurements of the two analyzers are linearly correlated, with the differences of reported water vapor mixing ratios from 36 ppm to 103 ppm for the range of reported water vapor mixing ratios from 1.09% to 2.11%. After correcting the water vapor measurements of CFADS 15 based on the water vapor measurements of CFADS 37, the water vapor correction functions from the experiments for CFADS 37 were applied to the experimental results of CFADS 15 (see Fig. 2e–f). Comparable residual errors (below 0.05 ppm for CO<sub>2</sub> and below 0.5 ppb for CH<sub>4</sub>) obtained from applying the same water correction functions to both experimental results for CFADS 37 and CFADS 15 proved that these correction functions are transferable from one instrument to another if the water vapor measurements are corrected to the same scale. The transferability between two individual analyzers suggests stability. However, the statistics from testing the two analyzers is still weak. Further water tests are ongoing with various analyzers.

Because the water vapor measurement by the analyzer is based on a single stable H<sub>2</sub>O spectroscopic feature which is spectrally close to the CH<sub>4</sub> spectral feature, we expect the measurement of the water vapor to exhibit the same highly stable performance over time that has been demonstrated on both CO<sub>2</sub> and CH<sub>4</sub>. Due to the difficulties in providing a known amount of water vapor, we cannot directly estimate the drift of water vapor accurately. However, we can use other stable gas measurements from the same analyzer (i.e. CO<sub>2</sub> and CH<sub>4</sub>) to estimate the drifts we might expect to see in H<sub>2</sub>O since the spectroscopy shares the same components (only the spectral lines are different). For CO<sub>2</sub> measurements, the observed peak-to-peak drift in an analyzer of the same type was 0.25 ppm over 170 days at a tall tower in Mead, Nebraska, USA (Crosson, 2008), which corresponds to a drift of 1 part in 1600 of the 400 ppm CO<sub>2</sub> concentration.

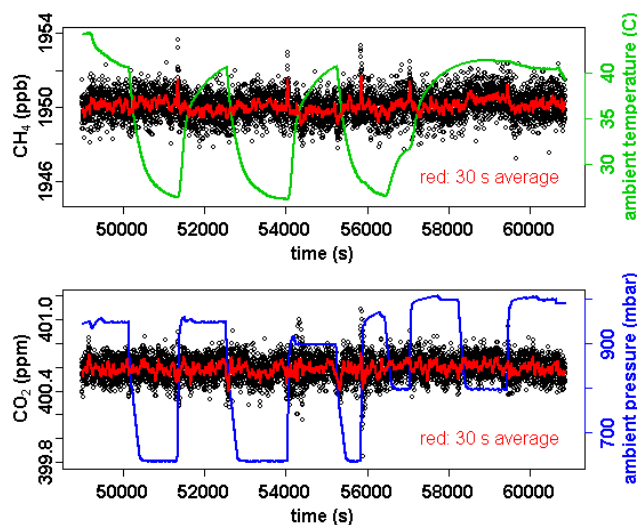

**Fig. 3.** CO<sub>2</sub> and CH<sub>4</sub> concentration measurements under simulated flight conditions. Variations of temperature and pressure are shown on the axis to the right.

That would indicate that a 4% water vapor concentration should drift by no more than 1 part in 1600 of 4%, or 25 ppm. A drift of 25 ppm in the water vapor concentration translates to a drift of only  $\sim 0.01$  ppm or  $\sim 0.05$  ppb in the final reported CO<sub>2</sub> and CH<sub>4</sub> mixing ratios respectively.

### 4 Performance under simulated flight conditions

A flight analyzer needs to be able to deal with the environmental temperature and pressure variations on board aircraft. As part of the work necessary to verify CRDS analyzer performance before deployment in the field, we applied temperature and pressure variations that typically occurred during flight. To this end we placed the CRDS analyzer in an environmental chamber (Siemens AG, Chemnitz, Germany, type CH3030) in an attempt to replicate the conditions found aboard a research aircraft (Bandeirante EMB 110) with a non-pressurized cabin flying over the Amazon rain forest in Brazil or aboard a commercial airliner (Airbus A340). The analyzer measured mixing ratios of CO<sub>2</sub> and CH<sub>4</sub> standard gases during the whole test period. The test results are shown in Fig. 3. The instrument ambient pressure ranged from 1000 mbar down to 640 mbar and temperature ranged from 44 °C down to 26 °C covering the expected range of cabin conditions typically found on board both aircraft. Note that the instrument aboard the Airbus A340 usually experiences ambient pressure down to 250 mbar, which was not tested during this experiment; however the inlet pressure control system of the analyzer is designed to cover this range of inlet pressures.

The measurements during laboratory pressure and temperature tests showed insignificant difference in the mean values and slightly larger noise under simulated flight conditions



( $400.59 \pm 0.09$  ppm for  $\text{CO}_2$  and  $1950.07 \pm 0.68$  ppb for  $\text{CH}_4$ ) compared to normal ambient conditions ( $400.59 \pm 0.07$  ppm for  $\text{CO}_2$  and  $1950.15 \pm 0.64$  ppb for  $\text{CH}_4$ ). The maximum pressure change rate was actually 5 times larger than what was expected to happen aboard a research aircraft or aboard a commercial aircraft due to the operational constraints of the environmental chamber. A few spikes at around 51 500, 54 000, 55 900, 57 000 s for  $\text{CH}_4$  and at around 54 200 and 55 900 s for  $\text{CO}_2$  have been observed. Note that these happened when the pressure values were increasing. The reason was that the pressure change rates during the pressure increasing period were much larger than expected pressure change rates during flight. Therefore, these spikes will not emerge during a real flight. The performance of the CRDS analyzer under simulated flight conditions implies high stability during later flight measurements.

One thing we need to point out is that we have observed a slight increase in the variations of the cavity pressure for several short periods during BARCA flight. We believe that an imperfect control of the sampling gas flow has been caused by mechanical vibrations, which leads to the variations in the cavity pressure. Two modifications have been made: one is to change the orientation of solenoid valves in the flow control unit from vertical to horizontal, because larger vertical vibrations are expected than horizontal vibrations during flight; the other is to modify the flow control frequency so that it is less influenced by the vibrations during flight. After these two modifications, the slightly larger variations in the cavity pressure for short periods have diminished to an insignificant level during later flights.

## 5 In-flight comparison of $\text{CO}_2$ mixing ratio measurements from the CRDS analyzer and an NDIR analyzer

Besides the CRDS analyzer, an NDIR  $\text{CO}_2$  analyzer (modified Li-Cor, Inc. LI-6251) was also flown on board the same aircraft during the entire campaign. This gives us an opportunity to compare the  $\text{CO}_2$  mixing ratio measurements from two independent analyzers. Several issues need to be addressed regarding the comparison: the response time of the analyzers and the time delay between the time air enters the inlet until it reaches the sample cell need to be estimated;  $\text{CO}_2$  mixing ratio measurements from the NDIR analyzer requires on-line calibrations using in-flight calibration gases; inter-laboratory comparability of  $\text{CO}_2$  standards and potential drift of the CRDS analyzer (this will be discussed in Sect. 6).

A detailed description of this NDIR instrument is given in Daube et al. (2002); here we only describe the points that are related to the comparison of  $\text{CO}_2$  mixing ratio measurements from the two analyzers. The NDIR analyzer consists of a near infrared light source, gas cells and a solid-state detector. It uses the strong absorption band of  $\text{CO}_2$  around  $4.26 \mu\text{m}$  and

is operated to perform differential measurements, with the sample air flows through the sample cell at the flow rate of 200 sccm (standard cubic centimeters per minute) and one calibration gas flows through the reference cell at the flow rate of 27 sccm. The cell volume is  $11.9 \text{ cm}^3$  and the pressure of the cell is controlled to  $\sim 450$  mbar. Besides, a bypass flow is introduced when the system is doing calibrations. The response time of the NDIR analyzer (90% response) is around 3.5 s. It employs a two-step drying system that is able to remove the water vapor in the sample air sufficiently and minimizes the effect on the instrument's response time. Four standard gases are used for in-flight  $\text{CO}_2$  calibrations. Three were used as calibration gases and the other one was used as a target gas for long term surveillance. The data from the NDIR analyzer were recorded at 4 Hz and were median-filtered within 2 s. A variable time delay correction was applied to the final data according to the inlet flow rate and estimated inlet volumes. The time delay during the BARCA phase B for the  $\text{CO}_2$  mixing ratio measurements from the NDIR analyzer was between 3.2 s and 4.1 s.

The CRDS analyzer measured the three species of  $\text{CO}_2$ ,  $\text{CH}_4$  and  $\text{H}_2\text{O}$  sequentially. Mixing ratios of  $\text{CO}_2$  were reported at time intervals of  $\sim 1.5$  s, while mixing ratios of  $\text{CH}_4$  and  $\text{H}_2\text{O}$  were reported at time intervals of 3.0 s. The timestamp of each measurement made by the CRDS analyzer corresponded to the completion of the spectral scan of each gas species, thus specifying the actual time when the sample was being measured to within a few hundred milliseconds. Laboratory tests showed that the sample flow rate ( $\sim 460$  sccm) of the CRDS analyzer was rather constant (less than 5% change) over the change of the ambient pressure from 330 mbar to 1330 mbar. The volume of the cavity of the CRDS analyzer is  $35 \text{ cm}^3$  and the pressure of the cell is controlled at  $\sim 140$  Torr ( $\sim 186$  mbar). The response time (90% response) of the CRDS analyzer was about 2 s. The time delay of between 6.3 s and 10 s was corrected based on the ambient pressure, the flow rate and estimated volumes of the inlet tube.

The time differences between the measurements of the two analyzers obtained by maximizing the correlation of the measurements in each individual flight are  $-0.2 \pm 1.2$  s, which is smaller than the time resolution of the CRDS analyzer (1.5 s) or of the reported NDIR results (2 s).

During the BARCA phase B campaign, 16 flights were made, including one test flight in Sao Jose dos Campos and 15 flights over the Amazon rain forest. Table 1 shows the comparisons of the measurements of the two  $\text{CO}_2$  analyzers. The missing values in the table are due to missing data for one of the analyzers or, in the worst case, both. The CRDS analyzer did not operate for two of the flights due to the failure of one temperature controller inside the analyzer for flights nos. 008 and 009, while the NDIR analyzer did not operate due to the failure of a pump in the case of flights nos. 009 and 010 and was not operated in the case of flight no. 014 to avoid catching rainwater.

With the test flight data removed (Flight No. 000), before which calibration gases had been sitting for almost half a year and during which the space inside the aircraft was severely overheated, the mean difference over all subsequent flights is  $0.22 \pm 0.09$  ppm, and the mean standard deviation of the difference is  $0.23 \pm 0.05$  ppm (see Table 1).

## 6 Cross-calibration during the BARCA campaign

In this section, we address the issues of inter-laboratory comparability of CO<sub>2</sub> standards from two different laboratories, and the potential drifts in the calibration gases or in the CO<sub>2</sub> mixing ratio measurements of the CRDS analyzer, with the aim to explain the mean difference of  $0.22 \pm 0.09$  ppm between the measurements of the two instruments (see Sect. 5).

As mentioned above, four in-flight calibration gases were used for the NDIR analyzer during the campaign. In addition, four filling tanks were employed to refill the internal small calibration cylinders in the NDIR analyzer whenever the pressure in these calibration cylinders dropped below  $\sim 3.4 \times 10^6$  Pa ( $\sim 34$  bar). Among the four filling tanks, three were calibrated at the Department of Earth and Planetary Sciences and the Division of Engineering and Applied Sciences at Harvard about one year prior to the campaign, and one reference gas tank was obtained in Brazil and calibrated by the flight NDIR analyzer in the field. All of the four filling tanks contained synthetic air.

The CRDS analyzer was calibrated using four ambient air standards in the laboratory of MPI-Jena, Germany, in January 2009, prior to shipment to Brazil. The CRDS analyzer response was linear, with residual errors for CO<sub>2</sub> below 0.02 ppm for the range from 354.71 ppm to 453.12 ppm and for CH<sub>4</sub> below 0.05 ppb for the range from 1804.73 ppb to 2296.69 ppb. No in-flight or ground calibrations for the CRDS analyzer were performed during the whole campaign; however, the four filling tanks used for refilling the in-flight calibration gas cylinders in the NDIR analyzer were measured by the CRDS analyzer immediately after the last flight of the campaign.

Both the Harvard and the MPI standard scales are traceable to the WMO CO<sub>2</sub> scales maintained in NOAA/ESRL (Zhao and Tans, 2006). However, there are potential causes for the mean difference of 0.22 ppm (see Table 1) between CO<sub>2</sub> concentration measurements from the NDIR and the CRDS analyzers: 1) CO<sub>2</sub> concentrations of Harvard standards might have drifted due to shipment and a one year storage period; 2) the CRDS analyzer might have drifted since the calibrations were made 4 months before the campaign. For further comparison, we tried to place the CRDS and the NDIR on the same calibration scale. To perform this, we used the measurements of the four filling tanks by the CRDS analyzer immediately after the last flight of the campaign and assigned the CO<sub>2</sub> concentrations derived from the CRDS measurements to the concentrations of in-flight calibration gases used

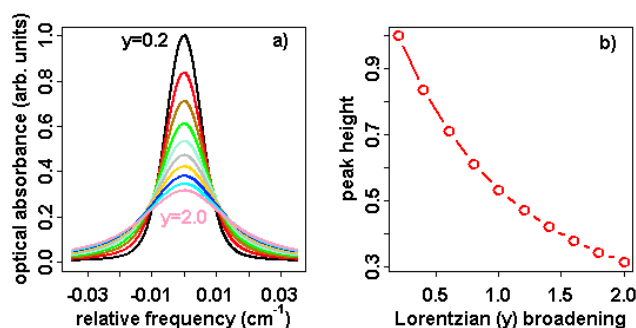

**Fig. 4.** (a) normalized absorption profiles for constant concentrations; (b) correlation between peak height and Lorentzian ( $\gamma$ ) broadening.

by the NDIR analyzer. Since the CRDS analyzer scans the spectrum of the absorption line of  $^{12}\text{C}^{16}\text{O}_2$  and uses the peak height obtained from the fit of the spectral line to determine the mixing ratio of total CO<sub>2</sub> in air, the measurements are sensitive to variations of compositions (N<sub>2</sub>, O<sub>2</sub> and Ar) due to pressure broadening and to variations of carbon isotopologues. Therefore, the measurements of the four standard gases need to be corrected for the pressure-broadening and the isotope effects.

Unfortunately, the inert background gas fractions (N<sub>2</sub>, O<sub>2</sub>, and Ar) of the four filling tanks have not been measured. However, the Lorentzian broadening parameter was measured as part of the field campaign, and that data, along with a laboratory investigation of the dependence of the peak height of the absorption lines on Lorentzian broadening, were used to correct the calibration tank data reported by the CRDS analyzer.

### 6.1 Corrections for the pressure-broadening effect

As noted above, any significant ( $> \sim 100$  ppm) changes in the composition of the matrix gas in the calibration tanks can lead to variations in the line broadening parameters, which can in turn lead to variations in the reported concentrations of carbon dioxide and methane for a constant mixing ratio. For the inert gases N<sub>2</sub>, O<sub>2</sub>, and Ar, this is not typically of concern in the well-mixed atmosphere, but it can be of concern for synthetic gas standards, where the concentrations of these inert gases can vary widely. Unfortunately, detailed measurements (or well-benchmarked calculations) of the Lorentzian and Galatry line shape parameters are not available for the optical transitions of carbon dioxide and methane in a background of varying N<sub>2</sub>, O<sub>2</sub>, and Ar. However, we can use direct measurements of the line broadening of the CO<sub>2</sub> absorption line to correct for the line broadening effects of the inert gas composition.

The high-resolution spectral profile of  $^{12}\text{C}^{16}\text{O}_2$  was recorded and was fitted using a Galatry profile model (Varghese and Hanson, 1984). In the Galatry model, pressure broadening consists of Lorentzian broadening (parameterized as



**Table 1.** Comparisons of CO<sub>2</sub> mixing ratio measurements from the CRDS analyzer and the NDIR analyzer on the Bandeirante EMB 110 aircraft during the BARCA phase B campaign in Brazil in 2009.

Flight No.	Date (mmdd)	Difference (ppm)	Difference 1σ (ppm)	Difference after cross-calibration (ppm)	Difference after cross-calibration 1σ (ppm)
000	0511	1.39	0.87	*	*
001	0515	0.28	0.20	*	*
002	0517	0.20	0.23	0.06	0.25
003	0517	0.22	0.20	0.06	0.20
004	0519	0.34	0.32	0.19	0.32
005	0519	0.21	0.28	0.03	0.26
006	0521	0.12	0.22	−0.04	0.22
007	0521	0.11	0.26	−0.05	0.25
008	0522	**	**	**	**
009	0523	**	**	**	**
010	0523	**	**	**	**
011	0526	0.20	0.18	0.03	0.19
012	0526	0.18	0.15	0.01	0.16
013	0527	0.38	0.23	0.22	0.23
014	0527	**	**	**	**
015	0528	0.21	0.22	0.03	0.22
Average (not including flight nos. 000 and 001)		0.22	0.23	0.05	0.23

\* The calibration gases used in these two flights were not measured by the CRDS analyzer.

\*\* Data missing from either of the two analyzers.

the variable  $y$ , line width) and line narrowing (parameterized as the variable  $z$ ). Both  $y$  and  $z$  vary depending on variation of the composition of the air. Ideally, changes in both  $y$  and  $z$  should be used to correct the pressure-broadening effect for measurements of synthetic air. However, the  $z$  parameter was not independently fitted during those measurements in Brazil, because the line-narrowing effect could not be clearly distinguished from noise in these data. This is due to the fact that the inert gas composition varied over a very small range of values in the filling tanks, and because the line-narrowing effect is of much smaller magnitude than the Lorentzian line broadening effect. Therefore, we only discuss correcting the pressure-broadening effect based on the variation in the  $y$  parameter, assuming that the  $z$  parameter is linearly correlated to the  $y$  parameter. For constant mixing ratios of CO<sub>2</sub> in air, the Galatry profiles vary according to  $y$  (with  $z$  proportional to  $y$ ), while the areas of the profiles are constant (see Fig. 4a). The correlation between the height and the width of the spectral profiles is shown in Fig. 4b. A simple Taylor expansion in the vicinity of the nominal  $y$ -value for ambient air predicts the following expression for the peak height as a function of  $y$ :

$$\frac{d[\text{peak}]}{dy} = B \times (y - y_{\text{nom}}) + A \quad (1)$$

Here [peak] represents the fractional change in the peak height, or  $\Delta\text{peak}/\text{peak}$ . For measurements of synthetic air standards, the  $y$  varies in such a very small range that  $\frac{d[\text{peak}]}{dy}$

can be regarded as a constant (i.e.  $B=0$ ). This constant value was determined from a laboratory experiment of measuring three synthetic air standards by a CRDS analyzer and a GC (Gas Chromatography) to be  $0.34 \pm 0.05$  (see Table 2, the units here are expressed in fraction of the Doppler broadened Gaussian width). Based on this correlation, we can correct the measured peak height using the  $y$  parameters to compensate the pressure-broadening effect due to variations of compositions in air.

The corrections for the pressure-broadening effect ranged from  $-0.22$  ppm to 1.68 ppm for the four filling tanks. The uncertainty of this correction is mainly caused by the noise in the  $y$  parameter due to noise in the loss and wavelength values of the individual data points that make up the complete spectrogram. It is important to note that this noise is the reason that we use peak height rather than peak area to quantify the gas concentration. For 5-min measurements of the filling tanks, the error of the mean of the pressure-broadening corrections is estimated to be 0.11 ppm.

## 6.2 Corrections for variations in carbon isotopologues

The CRDS analyzer measures the number of <sup>12</sup>C<sup>16</sup>O<sub>2</sub> molecules, and determines total CO<sub>2</sub> concentration by dividing the fractional abundance of <sup>12</sup>C<sup>16</sup>O<sub>2</sub> in ambient air according to the calibration of the CRDS analyzer in the laboratory. The fractional abundance of synthetic air can be different from that of ambient air since the CO<sub>2</sub> in the

**Table 2.** Total CO<sub>2</sub> concentrations of the four filling tanks used during BARCA, derived from the laboratory experiments of measuring synthetic air standards with known total CO<sub>2</sub> concentrations from GC.

Tanks	CRDS concentration readings (ppm)	$\Delta y^*$	$d[\text{peak}]/dy$	Total CO <sub>2</sub> concentrations from GC (ppm)	Total CO <sub>2</sub> concentration derived from the CRDS measurements (ppm)
Syn-1	406.71	0.0061±0.0006	0.32±0.03	407.59	–
Syn-2	392.36	0.0046±0.0009	0.30±0.06	392.84	–
Syn-3	372.47	0.0062±0.0009	0.39±0.06	373.11	–
Fill-1	363.13	−0.0018±0.0011	0.34±0.05**	–	362.70
Fill-2	371.90	0.0001±0.0012	0.34±0.05**	–	371.72
Fill-3	381.99	0.0130±0.0011	0.34±0.05**	–	383.40
Fill-4	404.43	0.0069±0.0010	0.34±0.05**	–	405.10

\*  $\Delta y$  was calculated as the difference between the mean values of  $y$ -parameters obtained from measuring a synthetic air standard and an ambient air standard, the values of  $y$  parameter range from 1.84 to 1.86.

\*\* This value is the mean of  $d[\text{peak}]/dy$  values derived from the laboratory experiments of measuring three synthetic air standards, i.e. Syn-1, Syn-2 and Syn-3.

synthetic air was from burned petroleum or natural gases. The isotopologues that could affect the measurements of total CO<sub>2</sub> by more than 0.01 ppm are <sup>13</sup>C<sup>16</sup>O<sub>2</sub> and <sup>12</sup>C<sup>16</sup>O<sup>18</sup>O (Tohjima et al., 2009).

Practically, their fractional abundance can be derived from measurements of <sup>13</sup>C/<sup>12</sup>C and <sup>18</sup>O/<sup>16</sup>O isotope ratios. In the following, we will discuss the impacts of variations in the two isotopologues on the CO<sub>2</sub> mixing ratio measurements by the CRDS analyzer. The isotope ratios of <sup>13</sup>C/<sup>12</sup>C are normally expressed as  $\delta^{13}\text{C}$  values and are defined as follows:

$$\delta^{13}\text{C}(\text{‰}) = \left[ \frac{{}^{13}\text{R}_{\text{sample}}}{{}^{13}\text{R}_{\text{reference}}} - 1 \right] \times 10^3 \quad (2)$$

Here  ${}^{13}\text{R}_{\text{sample}} = ({}^{13}\text{C}/{}^{12}\text{C})_{\text{sample}}$ ,  ${}^{13}\text{R}_{\text{reference}} = ({}^{13}\text{C}/{}^{12}\text{C})_{\text{reference}}$ . The  $\delta^{13}\text{C}$  values are expressed relative to the absolute <sup>13</sup>C/<sup>12</sup>C ratio of 0.011180±0.000028 for the reference materials of the Vienna Pee Dee Belemnite (VPDB) (Tohjima et al., 2009).

Similarly, the <sup>18</sup>O/<sup>16</sup>O isotopic ratios are expressed as  $\delta^{18}\text{O}$  values and are defined as

$$\delta^{18}\text{O}(\text{‰}) = \left[ \frac{{}^{18}\text{R}_{\text{sample}}}{{}^{18}\text{R}_{\text{reference}}} - 1 \right] \times 10^3 \quad (3)$$

Here  ${}^{18}\text{R}_{\text{sample}} = ({}^{18}\text{O}/{}^{16}\text{O})_{\text{sample}}$ ,  ${}^{18}\text{R}_{\text{reference}} = ({}^{18}\text{O}/{}^{16}\text{O})_{\text{reference}}$ .

The  $\delta^{18}\text{O}$  values are expressed relative to the ratio of Vienna Standard Mean Ocean Water (VSMOW), an isotopic water standard. The <sup>18</sup>O/<sup>16</sup>O ratio of the VSMOW is  $2.00520 \times 10^{-3}$  (Baertschi, 1976). When measuring synthetic air, the CRDS analyzer calculated the CO<sub>2</sub> mixing ratio by using the <sup>13</sup>C/<sup>12</sup>C and <sup>18</sup>O/<sup>16</sup>O ratios of ambient

air. The readings of synthetic CO<sub>2</sub> measurements can be expressed as:

$$\text{CO}_{2\text{meas}} = {}^{12}\text{C}^{16}\text{O}_2 \times (1 + {}^{13}\text{R}_{\text{amb}} + 2 \times {}^{18}\text{R}_{\text{amb}}) \quad (4)$$

However, the CO<sub>2</sub> mixing ratio of the synthetic air should be calculated as:

$$\text{CO}_{2\text{syn}} = {}^{12}\text{C}^{16}\text{O}_2 \times (1 + {}^{13}\text{R}_{\text{syn}} + 2 \times {}^{18}\text{R}_{\text{syn}}) \quad (5)$$

Here, CO<sub>2</sub> and <sup>12</sup>C<sup>16</sup>O<sub>2</sub> denote the total CO<sub>2</sub> mixing ratio and the mixing ratio of <sup>12</sup>C<sup>16</sup>O<sub>2</sub> respectively. From Eqs. (2–5), we can derive the equation for calculating CO<sub>2</sub> in the synthetic air

$$\text{CO}_{2\text{syn}} = \text{CO}_{2\text{meas}} \times \left[ \frac{1 + {}^{13}\text{R}_{\text{ref}} \times (1 + \delta^{13}\text{C}_{\text{syn}}) + 2 \times {}^{18}\text{R}_{\text{ref}} \times (1 + \delta^{18}\text{C}_{\text{syn}})}{1 + {}^{13}\text{R}_{\text{ref}} \times (1 + \delta^{13}\text{C}_{\text{amb}}) + 2 \times {}^{18}\text{R}_{\text{ref}} \times (1 + \delta^{18}\text{C}_{\text{amb}})} \right] \quad (6)$$

The  $\delta^{13}\text{C}$  and  $\delta^{18}\text{O}$  values of ambient CO<sub>2</sub> are around −8‰ on the VPDB scale (GLOBALVIEW-CO2C13, 2009) and around 42‰ on the VSMOW scale (Allison and Francey, 2007), respectively. Unfortunately, direct  $\delta^{13}\text{C}$  and  $\delta^{18}\text{O}$  measurements for the four filling tanks are not available and not easy to obtain due to logistic difficulties. An estimate for the  $\delta^{13}\text{C}$  and  $\delta^{18}\text{O}$  values of synthetic air, with CO<sub>2</sub> from burned petroleum or natural gas added (as used in the four filling tanks), can be given based on isotope-abundance variations (Coplen et al., 2002), which results in values for  $\delta^{13}\text{C}$  of  $-37 \pm 11\text{‰}$  on the VPDB scale, and for  $\delta^{18}\text{O}$  of  $24 \pm 10\text{‰}$  on the VSMOW scale. The corrections due to variations of  $\delta^{13}\text{C}$  and  $\delta^{18}\text{O}$  values for the filling tanks using these values are  $0.14 \sim 0.16 \pm 0.06$  ppm, which is a small correction range compared to the correction range for the above pressure-broadening effect.

**Table 3.** Assignment of CO<sub>2</sub> concentrations of the four filling tanks derived from the CRDS analyzer to the calibration gases used by the NDIR analyzer.

Tanks	Total CO <sub>2</sub> concentrations derived from the CRDS measurements (ppm)	Assigned concentrations to the NDIR calibration gases (ppm)*	Harvard calibrations (ppm)**	Differences between the assigned and Harvard calibrations (ppm)
Low span	362.70	362.79	362.87	-0.08
Target	371.72	371.81	371.61	0.20
Reference	383.40	383.49	383.30***	0.19
High span	405.10	405.19	405.41	-0.22

\* The concentrations from the CRDS measurements plus isotope corrections due to the isotope effect in the mixing ratio measurements by the NDIR technique.

\*\* Calibrations were done at Harvard University before shipment to Brazil in July 2008.

\*\*\* Not directly calibrated, but derived from the target calibration gas (due to logistic difficulties associated with exporting hazardous materials from Brazil).

**Table 4.** Uncertainties related to comparison between the two CO<sub>2</sub> analyzers.

Sources	Uncertainties (ppm)	Remarks
Water correction	0.05	Maximum residual error
Corrections for pressure broadening	0.11	The error of the mean of corrections for pressure broadening
Carbon isotope correction	0.06	Uncertainties in estimated $\delta^{13}\text{C}$ and $\delta^{18}\text{O}$ values
Carbon isotope effects on the NDIR analyzer	0.02	Variations of RMRs for different NDIR analyzers
Total uncertainty	0.14	

After the above described corrections, the total CO<sub>2</sub> values of the filling tanks were finally determined (see Table 3). However, the assigned values to the NDIR in-flight calibrations need to incorporate the isotopic effect for the original calibrations as well, since they were performed against ambient air standards by an NDIR analyzer (modified Li-Cor, Inc. LI-6251). The isotope effect of an NDIR analyzer can be evaluated based on the relative molar response (RMR) value of the NDIR analyzer and the difference in the mole fraction of the isotopologues between the ambient and the synthetic air (Tohjima et al., 2009). We employed the RMR values obtained by Tohjima et al. (2009) and the mole fraction differences described above to estimate the isotopic effect and found out the original calibrations were  $0.09 \pm 0.02$  ppm higher than corresponding total CO<sub>2</sub> mixing ratios. Notice that no correction was required when the NDIR analyzer was used to measure atmospheric air since the isotope effect was cancelled out. Therefore, the assigned value to the NDIR in-flight calibrations should be the determined total CO<sub>2</sub> values by the CRDS plus 0.09 ppm (see Table 3).

The differences between the values assigned to the NDIR and the Harvard calibration values are listed as well. The values assigned for the four tanks were applied as the standards to reprocess the NDIR data. The comparisons between the CRDS and the reprocessed NDIR data are shown in the last

two columns in Table 1. The mean difference between the two analyzers is reduced to  $0.05 \pm 0.09$  ppm. The uncertainties related to the comparison between the two CO<sub>2</sub> analyzers are summed up in Table 4. The total uncertainty related to the comparison is estimated to be 0.14 ppm. The high agreement between the measurements of the CRDS and the NDIR analyzers after placing them on the same scale proved that 1) the CRDS analyzer during the BARCA phase B campaign was highly stable ( $\sim 0.05$  ppm); 2) water corrections for CO<sub>2</sub> and CH<sub>4</sub> using simultaneously measured water vapor were fully adequate.

## 7 Conclusions

High-accuracy continuous measurements of greenhouse gases during the BARCA phase B campaign were achieved by an analyzer based on the cavity ring-down spectroscopy technique. Water correction functions derived from the laboratory experiments were used to correct the dilution and pressure-broadening effects due to variations of water vapor mixing ratios. The water correction functions have been shown to be transferable between different analyzers of the same type. The CRDS analyzer was highly stable under simulated flight conditions of varying environmental pressure

and temperature in an environmental chamber. The comparison of CO<sub>2</sub> measurements made by the CRDS analyzer and an NDIR analyzer on board the same aircraft showed a mean difference of  $0.22 \pm 0.09$  ppm, and a mean standard deviation of  $0.23 \pm 0.05$  ppm for all flights over the Amazon rain forest. Measurements of synthetic air from the filling tanks of the NDIR analyzer at the end of the campaign were carried out and the concentrations were determined after correcting for the variation in carbon isotopologues and for pressure-broadening effects due to variations of compositions in synthetic air. Application of these cross-calibrations reduced the mean of the difference between the CRDS and the NDIR during the campaign to  $0.05 \pm 0.09$  ppm. Due to the necessity of corrections for the isotope and pressure-broadening effects for CO<sub>2</sub> concentration measurements of synthetic air that introduces non-negligible uncertainties, we recommend using ambient air standards instead of synthetic air standards to calibrate a CRDS analyzer. The CRDS analyzer was highly stable without drying the sample air and without in-flight calibrations during the BARCA campaign phase B. The results clearly show that a single set of calibrations of the CRDS analyzer using ambient air standards during the aircraft campaign guarantees accuracy better than 0.05 ppm and the water corrections are fully adequate for high-accuracy continuous airborne measurements of CO<sub>2</sub> and CH<sub>4</sub>.

*Acknowledgements.* We are grateful for the efforts of the pilots Pedro Celso and Daniel Gramacho and the other BARCA team members P. Artaxo, F. Morais, A. C. Ribeiro, K. M. Longo, K. Wiedemann, M. D. P. Longo, M. A. F. de Silva Dias, L. Gatti, M. O. Andreae and N. Juergens. We are thankful for the discussions and information sharing with C. Sweeney and A. Karion. We also thank A. Jordan for discussions about standard gases and W. A. Brand for discussions about carbon isotopes. This work was supported by the European Commission through the IAGOS Design Study, an FP6 project. We thank the anonymous reviewers and Lukas Emmenegger for their comments that helped to improve this paper. Funding for the BARCA flights was provided by Max Planck Society, NASA and Millennium Institute of the Large Scale Biosphere – Atmosphere Experiment in Amazonia (LBA).

The service charges for this open access publication have been covered by the Max Planck Society.

Edited by: A. Zahn

## References

- Allison, C. E. and Francey, R. J.: Verifying Southern Hemisphere trends in atmospheric carbon dioxide stable isotopes, *J. Geophys. Res.-Atmos.*, 112, D21304, doi:10.1029/2006JD007345, 2007.
- Anderson, B. E., Gregory, G. L., Collins, J. E., Sachse, G. W., Conway, T. J., and Whiting, G. P.: Airborne observations of spatial and temporal variability of tropospheric carbon dioxide, *J. Geophys. Res.-Atmos.*, 101, 1985–1997, 1996.
- Baertschi, P.: Absolute O-18 Content of Standard Mean Ocean Water, *Earth Planet. Sc. Lett.*, 31, 341–344, 1976.
- Bischof, W.: Variations in Concentration of Carbon Dioxide in the Free Atmosphere, *Tellus*, 14, 87–90, 1962.
- Boering, K. A., Daube, B. C., Wofsy, S. C., Loewenstein, M., Podolske, J. R., and Keim, E. R.: Tracer-Tracer Relationships and Lower Stratospheric Dynamics – CO<sub>2</sub> and N<sub>2</sub>O Correlations During Spade, *Geophys. Res. Lett.*, 21, 2567–2570, 1994.
- Callendar, G. S.: Variations of the amount of carbon dioxide in different air currents, *Q. J. Roy. Meteor. Soc.*, 66, 395–400, 1940.
- Coplen, T. B., Bohlke, J. K., De Bievre, P., Ding, T., Holden, N. E., Hopple, J. A., Krouse, H. R., Lamberty, A., Peiser, H. S., Revesz, K., Rieder, S. E., Rosman, K. J. R., Roth, E., Taylor, P. D. P., Vocke, R. D., and Xiao, Y. K.: Isotope-abundance variations of selected elements – (IUPAC Technical Report), *Pure Appl. Chem.*, 74, 1987–2017, 2002.
- Crosson, E. R.: A cavity ring-down analyzer for measuring atmospheric levels of methane, carbon dioxide, and water vapor, *Appl. Phys. B-Lasers O.*, 92, 403–408, 2008.
- Daube, B. C., Boering, K. A., Andrews, A. E., and Wofsy, S. C.: A high-precision fast-response airborne CO<sub>2</sub> analyzer for in situ sampling from the surface to the middle stratosphere, *J. Atmos. Ocean. Technol.*, 19, 1532–1543, 2002.
- Frankenberg, C., Bergamaschi, P., Butz, A., Houweling, S., Meirink, J. F., Notholt, J., Petersen, A. K., Schrijver, H., Warneke, T., and Aben, I.: Tropical methane emissions: A revised view from SCIAMACHY onboard ENVISAT, *Geophys. Res. Lett.*, 35, L15811, doi:10.1029/2008GL034300, 2008.
- GLOBALVIEW-CO2C13: Cooperative Atmospheric Data Integration Project –  $\delta^{13}\text{C}$  of Carbon Dioxide, CD-ROM, NOAA ESRL, Boulder, Colorado [Also available via anonymous FTP to <ftp://ftp.cmdl.noaa.gov/ccg/co2c13/GLOBALVIEW/>, path: [ccg/co2c13/GLOBALVIEW](ftp://ftp.cmdl.noaa.gov/ccg/co2c13/GLOBALVIEW/)], 2009.
- Heimann, M.: Searching out the sinks, *Nat. Geosci.*, 2, 3–4, 2009.
- Houweling, S., Rockmann, T., Aben, I., Keppler, F., Krol, M., Meirink, J. F., Dlugokencky, E. J., and Frankenberg, C.: Atmospheric constraints on global emissions of methane from plants, *Geophys. Res. Lett.*, 33, L15821, doi:10.1029/2006GL026162, 2006.
- Jimenez, R., Herndon, S., Shorter, J. H., Nelson, D. D., McManus, J. B., and Zahniser, M. S.: Atmospheric trace gas measurements using a dual quantum-cascade laser n-dd-infrared absorption spectrometer, *P. Soc. Photo-Opt. Ins.*, 5738, 318–331, 2005.
- Keeling, C. D., Harris, T. B., and Wilkins, E. M.: Concentration of Atmospheric Carbon Dioxide at 500 and 700 Millibars, *J. Geophys. Res.*, 73, 4511–4528, 1968.
- Keppler, F., Hamilton, J. T. G., Brass, M., and Rockmann, T.: Methane emissions from terrestrial plants under aerobic conditions, *Nature*, 439, 187–191, 2006.

- Levin, I., Ciais, P., Langenfelds, R., Schmidt, M., Ramonet, M., Sidorov, K., Tchebakova, N., Gloor, M., Heimann, M., Schulze, E. D., Vygodskaya, N. N., Shibistova, O., and Lloyd, J.: Three years of trace gas observations over the EuroSiberian domain derived from aircraft sampling – a concerted action, *Tellus B*, 54, 696–712, 2002.
- Machida, T., Kita, K., Kondo, Y., Blake, D., Kawakami, S., Inoue, G., and Ogawa, T.: Vertical and meridional distributions of the atmospheric CO<sub>2</sub> mixing ratio between northern midlatitudes and southern subtropics, *J. Geophys. Res.-Atmos.*, 108(D3), 8401, doi:10.1029/2001JD000910, 2002.
- Machida, T., Matsueda, H., Sawa, Y., Nakagawa, Y., Hirokuni, K., Kondo, N., Goto, K., Nakazawa, T., Ishikawa, K., and Ogawa, T.: Worldwide Measurements of Atmospheric CO<sub>2</sub> and Other Trace Gas Species Using Commercial Airlines, *J. Atmos. Ocean. Technol.*, 25, 1744–1754, 2008.
- Miller, J. B., Gatti, L. V., d’Amelio, M. T. S., Crotwell, A. M., Dlugokencky, E. J., Bakwin, P., Artaxo, P., and Tans, P. P.: Airborne measurements indicate large methane emissions from the eastern Amazon basin, *Geophys. Res. Lett.*, 34, L10809, doi:10.1029/2006GL029213, 2007.
- Shashkov, A., Higuchi, K., and Chan, D.: Aircraft vertical profiling of variation of CO<sub>2</sub> over a Canadian Boreal Forest Site: a role of advection in the changes in the atmospheric boundary layer CO<sub>2</sub> content, *Tellus B*, 59, 234–243, 2007.
- Tans, P. P., Bakwin, P. S., and Guenther, D. W.: A feasible global carbon cycle observing system: A plan to decipher today’s carbon cycle based on observations, *Glob. Change Biol.*, 2, 309–318, 1996.
- Tohjima, Y., Katsumata, K., Morino, I., Mukai, H., Machida, T., Akama, I., Amari, T., and Tsunogai, U.: Theoretical and experimental evaluation of the isotope effect of NDIR analyzer on atmospheric CO<sub>2</sub> measurement, *J. Geophys. Res.-Atmos.*, 114, D13302, doi:10.1029/2009JD011734, 2009.
- Varghese, P. L. and Hanson, R. K.: Collisional Narrowing Effects on Spectral-Line Shapes Measured at High-Resolution, *Appl. Optics*, 23, 2376–2385, 1984.
- WMO: Report of the 11th WMO/IAEA Meeting of Experts on Carbon Dioxide Concentration and Related Tracer Measurement Techniques, Tokyo, Japan, 25–28 September 2001, Tech. Rep. 148, World Meteorological Organisation – Global Atmospheric Watch, Geneva, Switzerland, 2003.
- Zhao, C. L. and Tans, P. P.: Estimating uncertainty of the WMO mole fraction scale for carbon dioxide in air, *J. Geophys. Res.-Atmos.*, 111, D08S09, doi:10.1029/2005JD006003, 2006.