



# 4-Manifolds With Inequivalent Symplectic Forms and 3-Manifolds With Inequivalent Fibrations

## Citation

McMullen, Curtis T., and Clifford H. Taubes. 1999. 4-Manifolds with inequivalent symplectic forms and 3-manifolds with inequivalent fibrations. *Mathematical Research Letters* 6(5-6): 681–696. Revised 2003.

## Published Version

<http://www.mrlonline.org/mrl/>

## Permanent link

<http://nrs.harvard.edu/urn-3:HUL.InstRepos:3637160>

## Terms of Use

This article was downloaded from Harvard University's DASH repository, and is made available under the terms and conditions applicable to Other Posted Material, as set forth at <http://nrs.harvard.edu/urn-3:HUL.InstRepos:dash.current.terms-of-use#LAA>

## Share Your Story

The Harvard community has made this article openly available.  
Please share how this access benefits you. [Submit a story](#).

[Accessibility](#)

# 4-manifolds with inequivalent symplectic forms and 3-manifolds with inequivalent fibrations

Curtis T. McMullen and Clifford H. Taubes\*

22 August, 1999

## Abstract

We exhibit a closed, simply connected 4-manifold  $X$  carrying two symplectic structures whose first Chern classes in  $H^2(X, \mathbb{Z})$  lie in disjoint orbits of the diffeomorphism group of  $X$ . Consequently, the moduli space of symplectic forms on  $X$  is disconnected.

The example  $X$  is in turn based on a 3-manifold  $M$ . The symplectic structures on  $X$  come from a pair of fibrations  $\pi_0, \pi_1 : M \rightarrow S^1$  whose Euler classes lie in disjoint orbits for the action of  $\text{Diff}(M)$  on  $H_1(M, \mathbb{R})$ .

## 1 Introduction

**Symplectic 4-manifolds.** A *symplectic form*  $\omega$  on a smooth manifold  $X^{2n}$  is a closed 2-form such that  $\omega^n \neq 0$  pointwise. Given a pair of symplectic forms  $\omega_0$  and  $\omega_1$  on  $X$ , we say:

- (i)  $\omega_0$  and  $\omega_1$  are *homotopic* if there is a smooth family of symplectic forms  $\omega_t$ ,  $t \in [0, 1]$ , interpolating between them;
- (ii)  $\omega_0$  is a *pullback* of  $\omega_1$  if  $\omega_0 = f^*\omega_1$  for some diffeomorphism  $f : X \rightarrow X$ ; and
- (iii)  $\omega_0$  and  $\omega_1$  are *equivalent* if they are related by a combination of (i) and (ii).

---

\*This research was supported in part by the NSF. 1991 Mathematics Subject Classification: Primary 57R57, Secondary 57M25, 57N13.

Any symplectic form  $\omega$  admits a compatible almost complex structure  $J : TX \rightarrow TX$  (satisfying  $\omega(v, Jv) > 0$  for  $v \neq 0$ ). Let  $c_1(\omega) \in H^2(X, \mathbb{Z})$  denote the first Chern class of the (canonical) complex line bundle  $\wedge_{\mathbb{C}}^n TX$  determined by  $J$ . It is easy to see that the first Chern class is a deformation invariant of the symplectic structure; that is,  $c_1(\omega_0) = c_1(\omega_1)$  if  $\omega_0$  and  $\omega_1$  are homotopic.

The purpose of this note is to show:

**Theorem 1.1** *There exists a closed, simply-connected 4-manifold  $X$  which carries a pair of inequivalent symplectic forms. In fact,  $\omega_0$  and  $\omega_1$  can be chosen such that  $c_1(\omega_0)$  and  $c_1(\omega_1)$  lie in disjoint orbits for the action of  $\text{Diff}(X)$  on  $H^2(X, \mathbb{Z})$ .*

One can also formulate this result by saying that the moduli space  $\mathcal{M} = (\text{symplectic forms on } X) / \text{Diff}(X)$  is disconnected.

**Fibered 3-manifolds.** To construct the 4-dimensional example  $X$ , we first produce a compact 3-dimensional manifold  $M^3$  that fibers over the circle in two unrelated ways.

To describe this example, we recall the correspondence between closed 1-forms and measured foliations. Let  $\alpha$  be a closed 1-form on  $M$ , such that  $\alpha$  and its pullback to  $\partial M$  are pointwise nonzero. Then  $\alpha$  defines a *measured foliation*  $\mathcal{F}$  of  $M^3$ , transverse to  $\partial M$ , with  $T\mathcal{F} = \text{Ker } \alpha$  and with transverse measure  $\mu(T) = \int_T |\alpha|$ . Conversely, a (transversally oriented) measured foliation  $\mathcal{F}$  determines such a 1-form  $\alpha$ . If  $\alpha$  happens to have integral periods, then we can write  $\alpha = d\pi$  for a *fibration*  $\pi : M \rightarrow S^1 = \mathbb{R}/\mathbb{Z}$ , and the leaves of  $\mathcal{F}$  are then simply the fibers of  $\pi$ .

The *Euler class* of a measured foliation,

$$e(\mathcal{F}) = e(\alpha) \in H_1(M, \mathbb{Z}) / (\text{torsion}),$$

is represented geometrically by the zero set of a section  $s : M \rightarrow T\mathcal{F}$ , such that the vector field  $s|_{\partial M}$  is inward pointing and nowhere vanishing.

Just as for symplectic forms, we say:

- (i)  $\alpha_0$  and  $\alpha_1$  are *homotopic* if they are connected by a smooth family of closed 1-forms  $\alpha_t$ , nonvanishing on  $M$  and  $\partial M$ ;
- (ii)  $\alpha_0$  is a *pullback* of  $\alpha_1$  if  $\alpha_0 = f^*\alpha_1$  for some  $f \in \text{Diff}(M)$ ; and
- (iii)  $\alpha_0$  and  $\alpha_1$  are *equivalent* if they are related by a combination of (i) and (ii).

In the 3-dimensional arena we will show:

**Theorem 1.2** *There exists a compact link complement  $M = S^3 - \mathcal{N}(K)$  which carries a pair of inequivalent measured foliations  $\alpha_0$  and  $\alpha_1$ . In fact  $\alpha_0$  and  $\alpha_1$  can be chosen to be fibrations, with  $e(\alpha_0)$  and  $e(\alpha_1)$  in disjoint orbits for the action of  $\text{Diff}(M)$  on  $H_1(M, \mathbb{Z})$ .*

(Here and below,  $\mathcal{N}(K)$  denotes an open regular neighborhood of a link  $K$  in a 3-manifold.)

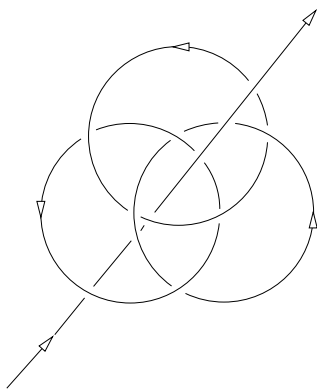

Figure 1. An axis added to the Borromean rings.

**Description of the manifolds.** For the specific examples we will present, the link  $K$  is obtained from the Borromean rings  $K_1 \cup K_2 \cup K_3$  by adding a fourth component  $K_4$ ; see Figure 1. The fourth component is the *axis* of a rotation of  $S^3$  cyclically permuting  $\{K_1, K_2, K_3\}$ ; it can be regarded as a vertical line in  $\mathbb{R}^3$ , normal to a plane nearly containing the rings.

Alternatively, we can also write  $M = T^3 - \mathcal{N}(L)$ , where

- $T^3 = \mathbb{R}^3/\mathbb{Z}$  is the flat Euclidean 3-torus,
- $L \subset T^3$  is a union of 4 disjoint, oriented, closed geodesics,
- $(L_1, L_2, L_3)$  gives a basis for  $H_1(T^3, \mathbb{Z})$ , and
- $L_4 = L_1 + L_2 + L_3$  in  $H_1(T^3, \mathbb{Z})$ .

The 4-manifold  $X$  of Theorem 1.1 is the fiber-sum of  $T^3 \times S^1$  with 4 copies of the elliptic surface  $E(1) \rightarrow \mathbb{CP}^1$ , with the elliptic fiber  $F \subset E(1)$

glued along  $L_i \times S^1$ . The key to the example is that  $\text{Diff}(X)$  preserves the *Seiberg–Witten norm*

$$\|s\|_{\text{SW}} = \sup\{|s \cdot t| : \text{SW}(t) \neq 0\}$$

on  $H^2(X, \mathbb{R})$ , just as  $\text{Diff}(M)$  preserves the Alexander norm on  $H^1(M, \mathbb{R})$ . The Seiberg–Witten norm manifests the rigidity of the smooth structure on  $X$ , allowing us to check that the Chern classes  $c_1(\omega_1), c_1(\omega_2)$  lie in different orbits of  $\text{Diff}(X)$ .

On the other hand, using Freedman’s work one can see that these two Chern classes *are* related by a homeomorphism of  $X$ . In fact, using the 3-torus we can write  $H^2(X, \mathbb{Z})$  with its intersection form as a direct sum

$$(H^2(X, \mathbb{Z}), \wedge) = (\mathbb{Z}^6, \begin{pmatrix} 0 & I \\ I & 0 \end{pmatrix}) \oplus (V, q),$$

where the Chern classes  $c_1(\omega_1), c_1(\omega_2)$  lie in the first factor and are related by an integral automorphism preserving the hyperbolic form. By Freedman’s result [FQ, §10.1], this automorphism of  $H^2(X, \mathbb{Z})$  is realized by a homeomorphism of  $X$ .

Many more examples can be constructed along similar lines. For a simple variation, one can replace  $L_4$  with a geodesic homologous to  $L_1 + L_2 + (2m + 1) \cdot L_3$ ,  $m \in \mathbb{Z}$ , and replace the elliptic surface  $E(1)$  with its  $n$ -fold fiber sum,  $E(n)$ . The manifolds  $M$  and  $X$  resulting from these variations also satisfy the Theorems above.

3-manifolds	4-manifolds
Measured foliations $\mathcal{F}$ of $M$	Symplectic forms $\omega$ on $X$
Fibrations $M \rightarrow S^1$	Integral symplectic forms
Fibers minimize genus	Pseudo-holomorphic curves minimize genus
Euler class $e(T\mathcal{F})$	First Chern class $c_1(\wedge_{\mathbb{C}}^2 TX)$
Alexander polynomial $\Delta_M \in \mathbb{Z}[H_1]$	Seiberg–Witten polynomial $\sum \text{SW}(t) \cdot t \in \mathbb{Z}[H^2]$
Alexander norm on $H^1(M, \mathbb{R})$	Seiberg–Witten norm on $H^2(X, \mathbb{R})$

Table 2.

**Notes and references.** Our examples exploit a dictionary between 3 and 4 dimensions, some of whose entries are summarized in Table 2.

The connection between the Thurston norm and the Seiberg–Witten invariant was developed by Kronheimer and Mrowka in [KM], [Kr2], [Kr1], while the work of Meng–Taubes and Fintushel–Stern brought the Alexander polynomial into play [MeT], [FS1], [FS2], [FS3]. Inasmuch as the Alexander polynomial is tied to the Thurston norm in [Mc2], [Mc1], (see also [Vi]), there is an intriguing circle of ideas here which might be better understood.

## 2 The Alexander and Thurston norms

In this section we recall the Alexander and Thurston norms for a 3-manifold, and prove that Theorem 1.2 holds for the link complement pictured in the Introduction.

**The Thurston norm.** Let  $M$  be a compact, connected, oriented 3-manifold, whose boundary (if any) is a union of tori. For any compact oriented  $n$ -component surface  $S = S_1 \sqcup \cdots \sqcup S_n$ , let

$$\chi_-(S) = \sum_{\chi(S_i) < 0} |\chi(S_i)|.$$

The *Thurston norm* on  $H^1(M, \mathbb{Z})$  measures the minimum complexity of a properly embedded surface  $(S, \partial S) \subset (M, \partial M)$  dual to a given cohomology class; it is given by

$$\|\phi\|_T = \inf\{\chi_-(S) : [S] = \phi\}.$$

The Thurston norm extends by linearity to  $H^1(M, \mathbb{R})$ .

Let  $B_T = \{\phi : \|\phi\|_T \leq 1\}$  denote the unit ball in the Thurston norm; it is a finite polyhedron in  $H^1(M, \mathbb{R})$ . A basic result is:

**Theorem 2.1** *Suppose  $\phi_0 \in H^1(M, \mathbb{Z})$  is represented by a fibration  $M \rightarrow S^1$  with fiber  $S$ . Then:*

- $\|\phi_0\|_T = \chi_-(S)$ ;
- $\phi_0$  is contained in the open cone  $\mathbb{R}_+ \cdot F$  over a top-dimensional face  $F$  of the Thurston norm ball  $B_T$ ;
- every cohomology class in  $H^1(M, \mathbb{Z}) \cap \mathbb{R}_+ \cdot F$  is represented by a fibration;
- the classes in  $H^1(M, \mathbb{R}) \cap \mathbb{R}_+ \cdot F$  are represented by measured foliations; and

- the Euler class  $e = e(\phi_0) \in H_1(M, \mathbb{Z})$  is dual to the supporting hyperplane to  $F$ . More precisely,  $\phi(e) = -1$  for all  $\phi \in F$ .

In this case we say  $F$  is a *fibred face* of the Thurston norm ball. For more details, see [Th2] and [Fr].

**The Alexander norm.** Next we discuss the Alexander polynomial and its associated norm. Let  $G = H_1(M, \mathbb{Z})/(\text{torsion}) \cong \mathbb{Z}^{b_1(M)}$ . The *Alexander polynomial*  $\Delta_M$  is an element of the group ring  $\mathbb{Z}[G]$ , well-defined up to a unit and canonically determined by  $\pi_1(M)$ . It can be effectively computed from a presentation for  $\pi_1(M)$  (see e.g. [CF]). Writing

$$\Delta_M = \sum_G a_g \cdot g,$$

the *Newton polygon*  $N(\Delta_M) \subset H_1(M, \mathbb{R})$  is the convex hull of the set of  $g$  such that  $a_g \neq 0$ . The *Alexander norm* on  $H^1(M, \mathbb{R})$  measures the length of the image of the Newton polygon under a cohomology class  $\phi : H_1(M, \mathbb{R}) \rightarrow \mathbb{R}$ ; that is,

$$\|\phi\|_A = |\phi(N(\Delta_M))|.$$

From [Mc2] we have:

**Theorem 2.2** *If  $M$  is a 3-manifold with  $b_1(M) \geq 2$ , then we have*

$$\|\phi\|_A \leq \|\phi\|_T$$

for all  $\phi \in H^1(M, \mathbb{R})$ ; and equality holds if  $\phi$  is represented by a fibration  $M \rightarrow S^1$ .

**Links in the 3-torus.** We now turn to the Thurston norm for link-complements in the 3-torus. Let  $T^3 = \mathbb{R}^3/\mathbb{Z}^3$  denote the flat Euclidean 3-torus. Every nonzero cohomology class  $\phi \in H^1(T^3, \mathbb{Z})$  is represented by a fibration (indeed, a group homomorphism)  $\Phi : T^3 \rightarrow S^1$ .

Consider an  $n$ -component link  $L \subset T^3$ , consisting of disjoint, oriented, closed geodesics  $L_1 \cup \dots \cup L_n$ . Define a norm on  $H^1(T^3, \mathbb{R})$  by

$$\|\phi\|_L = \sum |\phi(L_i)|, \tag{2.1}$$

where the  $L_i$  are considered as elements of  $H_1(M, \mathbb{Z})$ . Let  $M$  be the link complement  $T^3 - \mathcal{N}(L)$ , equipped with the natural inclusion  $M \subset T^3$ .

**Theorem 2.3** Given  $\phi \in H^1(T^3, \mathbb{Z})$ , let  $\psi$  denote its pullback to  $M = T^3 - \mathcal{N}(L)$ . Then we have:

$$\|\phi\|_L = \|\psi\|_T = \|\psi\|_A. \quad (2.2)$$

Moreover:

- (a)  $\psi$  is represented by a fibration  $\Psi : M \rightarrow S^1 \iff$
- (b)  $\phi(L_i) \neq 0$  for all  $i \iff$
- (c)  $\phi$  belongs to the open cone over a top-dimensional face of the norm ball  $B_L = \{\phi : \|\phi\|_L \leq 1\} \subset H^1(T^3, \mathbb{R})$ .

**Proof.** We begin by showing (a-c) are equivalent. If  $\psi$  is represented by a fibration  $\Psi : M \rightarrow S^1$ , then the fibers are transverse to  $\partial M$  and thus  $\phi(L_i) \neq 0$  for all  $i$ . On the other hand, the latter condition insures that the linear fibration  $\Phi : T^3 \rightarrow S^1$  associated to  $\phi$  restricts to a fibration of  $M$  representing  $\psi$ , so we have (a)  $\iff$  (b). Finally  $\|\phi\|_L$  behaves linearly on  $H^1(T^3, \mathbb{R})$  unless one of the terms  $\phi_i(L)$  changes sign, and thus the cone on the top dimensional faces is exactly the locus where  $\phi(L_i) \neq 0$  for all  $i$ , showing (b)  $\iff$  (c).

To establish equation (2.2), first suppose  $\psi$  is represented by a fibration  $\Psi : M \rightarrow S^1$  with fiber  $S$ . Since we may take  $\Psi = \Phi|_M$ , we see  $S$  is a union of tori with  $\sum |\phi(L_i)|$  punctures, and thus

$$\chi_-(S) = \|\psi\|_T = \sum |\phi(L_i)| = \|\phi\|_L.$$

Equality with the Alexander norm holds by Theorem 2.2.

Thus (2.2) holds on the cone over the top-dimensional faces of  $B_L$ . Since this cone is dense, (2.2) holds throughout  $H^1(T^3, \mathbb{Z})$  by continuity.  $\blacksquare$

**The Borromean rings plus axis.** We now turn to the study of the 4-component link  $K \subset S^3$  pictured in Figure 1. Let  $M = S^3 - \mathcal{N}(K)$ , and let  $m_i$  denote the meridian linking  $K_i$  positively. Then  $(m_1, m_2, m_3, m_4)$  forms a basis for  $H_1(M, \mathbb{Z}) \cong \mathbb{Z}^4$ , and the Alexander polynomial  $\Delta_M$  can be written as a Laurent polynomial in these variables.

**Lemma 2.4** The Alexander polynomial of  $M = S^3 - \mathcal{N}(K)$  is given by

$$\begin{aligned} \Delta_M(x, y, z, t) = & -4 + \left(t + \frac{1}{t}\right) - \left(xy + \frac{1}{xy} + yz + \frac{1}{yz} + xz + \frac{1}{xz}\right) \\ & + \left(xyz + \frac{1}{xyz}\right) + \left(x + \frac{1}{x} + y + \frac{1}{y} + z + \frac{1}{z}\right), \end{aligned}$$



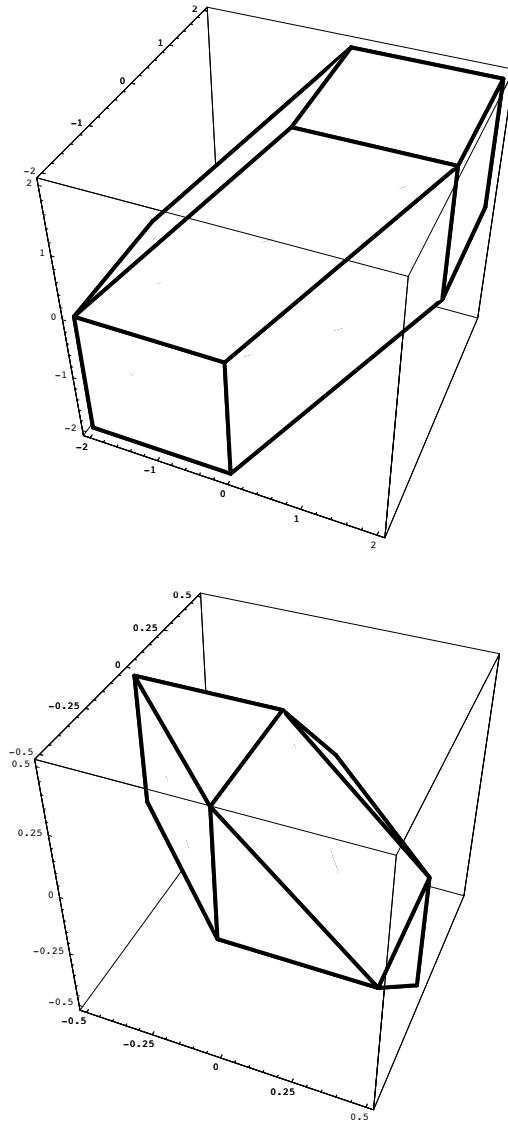

Figure 3. The Newton polygon of  $\Delta_M(x, y, z, 1)$  (top), and its dual.

where  $(x, y, z, t) = (m_1, m_2, m_3, m_4)$ .

**Proof.** The projection in Figure 1 yields the Wirtinger presentation

$$\begin{aligned} \pi_1(M) = \langle a, b, c, d, e, f, g, h, i, j, k, l : \\ aj = jb, bi = ic, gc = ag, dc = ce, ae = fa, fj = jd, \\ ge = eh, hj = ji, di = gd, jg = gk, kc = cl, le = ej \rangle. \end{aligned}$$

Here  $(a, b, c)$ ,  $(d, e, f)$ ,  $(g, h, i)$  and  $(j, k, l)$  are the edges of  $K_1$ ,  $K_2$ ,  $K_3$  and  $K_4$  respectively. Given this presentation, the calculation of  $\Delta_M$  is a straightforward application of the Fox calculus [Fox].  $\blacksquare$

Figure 3 shows the intersection of the Newton polygon  $N(\Delta_M)$  with the  $(x, y, z)$ -hyperplane.

To bring the 3-torus into play, recall that 0-surgery along the Borromean rings determines a diffeomorphism

$$S^3 - \mathcal{N}(K_1 \cup K_2 \cup K_3) \cong T^3 - \mathcal{N}(L_1 \cup L_2 \cup L_3),$$

where  $(L_1, L_2, L_3)$  are disjoint closed geodesics forming a basis for  $H_1(T^3, \mathbb{Z})$ . Under this surgery, the meridians  $(m_1, m_2, m_3)$  go over to longitudes of  $(L_1, L_2, L_3)$ . On the other hand,  $K_4$  goes over to the isotopy class of a geodesic  $L_4 \subset T^3$ , with

$$L_4 = L_1 + L_2 + L_3 \quad \text{in } H_1(T^3, \mathbb{Z}).$$

(To check the homology class of  $L_4$ , note that in  $S^3$  we have  $\text{lk}(K_i, K_4) = 1$  for  $i = 1, 2, 3$ .)

The meridian  $m_4$  goes over to a meridian of  $L_4$ , so unlike  $(m_1, m_2, m_3)$  it becomes trivial in  $H_1(T^3, \mathbb{Z})$ . Thus we have:

$$H^1(M, \mathbb{R}) \supset H^1(T^3, \mathbb{R}) = (\mathbb{R} \cdot m_4)^\perp.$$

**Lemma 2.5** *The action of  $\text{Diff}(M)$  on  $H^1(M, \mathbb{R})$  preserves the subspace  $H^1(T^3, \mathbb{R})$ .*

**Proof.** Consider the Newton polygon

$$N = N(\Delta_M) \subset H_1(M, \mathbb{R}),$$

where  $\Delta_M$  is given by Proposition 2.4. Since  $(t + 1/t)$  is the only expression in  $\Delta_M$  involving  $t$ , we have  $N = N_0 + [-1, 1] \cdot t$  where

$$N_0 = N(\Delta_M(x, y, z, 1))$$

is the polyhedron in  $(x, y, z)$ -space shown in Figure 3. The vertices  $\pm t$  of  $N$  are thus combinatorially distinguished: they are the endpoints of 14 edges of  $N$  (coming from the 14 vertices of  $N_0$ ), whereas all other vertices of  $N$  have degree 5. Since  $\text{Diff}(X)$  preserves  $N$ , it also stabilizes the special vertices  $\{\pm t\}$ , and thus  $\text{Diff}(X)$  stabilizes  $H^1(T^3, \mathbb{R}) = (\mathbb{R} \cdot t)^\perp = (\mathbb{R} \cdot m_4)^\perp$ . ■

**Proof of Theorem 1.2.** For our chosen link  $L \subset T^3$ , we have

$$\|\phi\|_L = |\phi(m_1)| + |\phi(m_2)| + |\phi(m_3)| + |\phi(m_1 + m_2 + m_3)|.$$

The unit ball  $B_L \subset H^1(T^3, \mathbb{R})$  of this norm is shown in Figure 3 (bottom); it is dual to the convex body  $N_0$ .

Note that  $B_L$  has both triangular and quadrilateral faces. Pick integral classes  $\phi_0, \phi_1 \in H^1(T^3, \mathbb{Z})$  lying inside the cones over faces  $F_0$  and  $F_1$  of different types, and let  $\alpha_0, \alpha_1 \in H^1(M, \mathbb{Z})$  denote their pullbacks to  $M$ .

By Theorem 2.3, the classes  $\alpha_0$  and  $\alpha_1$  correspond to fibrations  $M \rightarrow S^1$ . On the other hand,  $\text{Diff}(M)$  preserves the subspace  $H^1(T^3, \mathbb{R}) \subset H^1(M, \mathbb{R})$  as well as the norm  $\|\phi\|_L = \|\alpha\|_T$  on this subspace. Thus  $\text{Diff}(M)$  preserves  $B_L$ , so it cannot send the face  $F_0$  to  $F_1$ . The supporting hyperplanes for  $\alpha_0$  and  $\alpha_1$  in  $B_T$  thus lie in different orbits of  $\text{Diff}(M)$ . But these supporting hyperplanes are represented by  $e(\alpha_0)$  and  $e(\alpha_1)$ , so their Euler classes are in different orbits as well. ■

**The Thurston norm.** As was shown in [Mc2], the Alexander and Thurston norms agree for many simple links. The norms agree for the Borromean rings plus axis  $K \subset S^3$  as well.

To see this, note that  $K$  can be presented as the closure of a 3-strand braid wrapping once around the axis  $K_4 \subset K$ . A disk spanning  $K_4$  and transverse to  $K_1 \cup K_2 \cup K_3$  determines a fibered face  $F$  of the Thurston norm ball  $B_T$ . As observed by N. Dunfield, one can use the Teichmüller polynomial [Mc1] to show that for any 3-strand braid, the fibered face  $F$  coincides with a face of the Alexander norm ball  $B_A$ . In the example at hand, all the vertices of  $B_A$  are contained in  $\pm F$ , so we have  $B_A \subset B_T$  by convexity. The reverse inclusion comes from the general inequality  $\|\phi\|_A \leq \|\phi\|_T$ .

**Further example: a closed 3-manifold.** To conclude, we describe a *closed* 3-manifold  $N$  which fibers over the circle in two inequivalent ways.

Let  $M = T^3 - \mathcal{N}(L) = S^3 - \mathcal{N}(K)$  be the link complement considered above. Note that the longitudes of  $K_1, K_2$  and  $K_3$  are all homologous to the meridian  $m_4$  of  $K_4$ , since the components of the Borromean rings are

unlinked, while each component links  $K_4$  once. Since  $T^3$  is obtained by 0-surgery on  $K$ , all the meridians of  $L$  are homologous to  $m_4$ .

Now let  $N \rightarrow T^3$  be the 2-fold covering, branched over  $L$ , determined by the homomorphism

$$\xi : H_1(M, \mathbb{Z}) \rightarrow \{-1, 1\}$$

satisfying  $\xi(m_1) = \xi(m_2) = \xi(m_3) = 1$  and  $\xi(m_4) = -1$ .

The pullback map  $H^1(T^3, \mathbb{R}) \rightarrow H^1(N, \mathbb{R})$  is easily seen to be injective. We claim it is an isomorphism. To see surjectivity, let  $N' \subset N$  be the preimage of  $M \subset T^3$ . Decomposing  $H^1(N', \mathbb{R})$  into eigenspaces for the action of the  $\mathbb{Z}/2$  deck group for  $N' \rightarrow M$ , we obtain an isomorphism

$$H^1(N', \mathbb{R}) \cong H^1(M, \mathbb{R}) \oplus H^1(M, \mathbb{R}_\xi),$$

where the last term represents cohomology coefficients twisted by the character  $\xi$  of  $\pi_1(M)$ . Since  $\Delta_M(\xi) = \Delta_M(1, 1, 1, -1) = 4 \neq 0$ , we have  $H^1(M, \mathbb{R}_\xi) = 0$  (cf. [Mc2, §3]). Thus any cohomology class in  $H^1(N, \mathbb{R})$  restricts to a  $\mathbb{Z}/2$ -invariant class on  $N'$ , so it is the pullback of a class on  $T^3$ .

Moreover, every fibration of  $T^3$  transverse to  $L$  lifts to a fibration of  $N$ , so we find:

**Theorem 2.6** *The Thurston norm ball  $B_T \subset H^1(N, \mathbb{R})$  agrees with the norm ball  $B_L \subset H^1(T^3, \mathbb{R})$ , and every face is fibered.*

Picking fibrations in combinatorially inequivalent faces of  $B_T$  as before, we have:

**Corollary 2.7** *The closed 3-manifold  $N$  admits a pair of fibrations  $\alpha_0, \alpha_1$  such that  $e(\alpha_0), e(\alpha_1)$  lie in disjoint orbits for the action of  $\text{Diff}(N)$  on  $H^2(N, \mathbb{Z})$ .*

### 3 Fiber sum and symplectic 4-manifolds

In this section we recall the fiber sum construction, which can be used to canonically associate a 4-manifold  $X = X(P, L)$  to a link  $L$  in a 3-manifold  $P$ . Under this construction, suitable fibrations of  $P$  give symplectic forms on  $X(P, L)$ , and the Alexander polynomial  $\Delta_M$  of  $M = P - \mathcal{N}(L)$  determines Seiberg–Witten invariants of  $X$ . It is then straightforward to prove Theorem 1.1 by taking  $X = X(T^3, L)$ , where  $L \subset T^3$  is the 4-component link discussed in previous sections.

**Fiber sum.** Let  $f_i : T^2 \times D^2 \rightarrow X_i$ ,  $i = 1, 2$  be smooth embeddings of the torus cross a disk into a pair of smooth closed 4-manifolds. Let

$$X'_i = X_i - f(T^2 \times \text{int } D^2);$$

it is a smooth manifold whose boundary is marked by  $T^2 \times S^1$ . The *fiber sum*  $Z$  of  $X_1$  and  $X_2$  is the closed smooth manifold obtained by gluing together  $X'_1$  and  $X'_2$  along their boundaries, such that  $(x, t) \in \partial X'_1$  is identified with  $(x, -t) \in \partial X'_2$ . We denote the fiber sum by

$$Z = X_1 \#_{T_1=T_2} X_2,$$

where  $T_i = f(T^2 \times \{0\}) \subset X_i$ ; note that there is an implicit identification between the normal bundles of the tori  $T_i$ .

The fiber sum of symplectic manifolds along symplectic tori is also symplectic. More precisely, if  $\omega_i$  are symplectic forms on  $X_i$  with  $\omega_i > 0$  on  $T_i$  and  $\int_{T_1} \omega_1 = \int_{T_2} \omega_2$ , then  $Z$  carries a natural symplectic form  $\omega$  with  $\omega = \omega_i$  on  $X'_i$ .

For more details, see [Go], [MW], [FS1], [FS2], [FS3].

**The elliptic surface  $E(1)$ .** A convenient 4-manifold for use in the fiber-sum construction is the *rational elliptic surface*  $E(1)$ . The complex manifold  $E(1)$  is obtained by blowing up the base-locus for a generic pencil of elliptic curves on  $\mathbb{C}\mathbb{P}^2$ . Thus  $E(1)$  is isomorphic to  $\mathbb{C}\mathbb{P}^2 \# 9\overline{\mathbb{C}\mathbb{P}^2}$ ; it is simply-connected and unique up to diffeomorphism. The pencil provides a holomorphic map  $E(1) \rightarrow \mathbb{C}\mathbb{P}^1$  with generic fiber  $F$  an elliptic curve, and the canonical bundle of  $E(1)$  is represented by the divisor  $-F$ .

The projection  $E(1) \rightarrow \mathbb{C}\mathbb{P}^1$  gives a natural trivialization of the normal bundle of the fiber torus  $F$ . Since  $F \subset E(1)$  is a holomorphic curve in a projective variety, there is a symplectic (Kähler) form on  $E(1)$  with  $\omega|_F > 0$ .

Each of the nine exceptional divisors gives a holomorphic section

$$s : \mathbb{P}^1 \rightarrow E(1).$$

In particular, a meridian for the fiber  $F$  is contractible in  $E(1) - \mathcal{N}(F)$ , since it bounds the image of a disk under  $s$ . Since  $E(1)$  is simply-connected, any loop in the complement of  $F$  is homotopic to a product of conjugates of meridians, so  $E(1) - \mathcal{N}(F)$  is also simply-connected.

For a detailed discussion of the topology of elliptic surfaces, see [HKK, §1] or [GS].

**From links to 4-manifolds.** Now let  $L \subset P^3$  be a framed  $n$ -component link in a closed, oriented 3-manifold. Such a link determines:

- a 3-dimensional *link complement*  $M = P - \mathcal{N}(L)$ , and
- a 4-dimensional *fiber-sum*  $X = X(P, L) = (P \times S^1) \underset{L \times S^1 = nF}{\#} nE(1)$ .

To describe the fiber-sum in more detail, note that each component  $L_i$  of  $L$  determines a torus

$$T_i = L_i \times S^1 \subset P \times S^1,$$

and the framing of  $L_i$  provides a trivialization of the normal bundle of  $T_i$ . Take  $n$  copies of the elliptic surface  $E(1)$  with fiber  $F$ ; as remarked above, the projection  $E(1) \rightarrow \mathbb{C}\mathbb{P}^1$  provides a natural trivialization of the normal bundle of  $F$ . Finally, choose an orientation-preserving identification between  $L \times S^1$  and  $nF$ . The fiber-sum  $X(P, L)$  is then defined using these identifications.

It turns out that every orientation-preserving diffeomorphism of  $F$  extends to a diffeomorphism of  $E(1)$ , preserving the normal data; indeed, the monodromy of the fibration  $E(1) \rightarrow \mathbb{C}\mathbb{P}^1$  is the full group  $SL_2(\mathbb{Z})$ . Thus the diffeomorphism type of  $X(P, L)$  is the same for any choice of identification between  $L \times S^1$  and  $nF$ .

**Proposition 3.1** *The fiber-sum  $X$  is simply-connected if  $\pi_1(M)$  is normally generated by  $\pi_1(\partial M)$  (e.g. if  $M$  is homeomorphic to a link complement in  $S^3$ ).*

**Proof.** When the simply-connected manifolds  $n(E(1) - \mathcal{N}(F))$  are attached to  $M \times S^1$  along  $\partial M \times S^1$ , they kill  $\pi_1(\partial M \times S^1)$  by van Kampen's theorem. Since the latter groups normally generate  $\pi_1(M \times S^1)$ , the resulting manifold  $X$  is simply-connected. ■

**Promotion of cycles.** The fiber-sum construction furnishes us with an inclusion  $M \times S^1 = (P \times S^1)' \subset X$ .

**Proposition 3.2** *The map*

$$i : H_1(M, \mathbb{R}) \rightarrow H^2(X, \mathbb{R}),$$

*sending a 1-cycle  $\gamma \subset M$  to the Poincaré dual of  $\gamma \times S^1 \subset X$ , is injective.*

**Proof.** The map  $i$  is a composition of three maps:

$$H_1(M) \rightarrow H_2(M \times S^1) \rightarrow H_2(X) \rightarrow H^2(X).$$

The first arrow is part of the Künneth isomorphism, and the last comes from Poincaré duality, so they are both injective. As for the middle arrow

$$H_2(M \times S^1) \rightarrow H_2(X),$$

we can use the exact sequence of the pair  $(X, M \times S^1)$  to identify its kernel with

$$H_3(X, M \times S^1) \cong H_3(nE(1), nF) \cong H^1(nE(1) - nF) = 0.$$

Here we have used excision, Poincaré duality and the simple-connectivity of  $E(1) - F$ . Thus all three arrows are injective, and so  $i$  is injective. ■

**Corollary 3.3** *For an  $n$ -component link, we have*

$$b_2^+(X(P, L)) \geq b_1(M) \geq n.$$

Here  $b_2^+(X)$  denotes the rank of the maximal subspace of  $H_2(X, \mathbb{R})$  on which the intersection form is positive-definite.

**Proof.** Since 1-cycles in general position on  $M$  are disjoint, the intersection form on  $H^2(X, \mathbb{R})$  restricts to zero on  $i(H_1(M, \mathbb{R}))$ . But the intersection form is non-degenerate, so it must admit a positive (and negative) subspace of dimension at least  $b_1(M) = \dim i(H_1(M, \mathbb{R}))$ .

For the second inequality, just note that we have  $b_1(M) \geq b_1(\partial M)/2 = n$ . Indeed, by Lefschetz duality, the kernel of  $H_1(\partial M) \rightarrow H_1(M)$  is Lagrangian, so the image has dimension  $n$ . ■

**From fibrations to symplectic forms.** A central point for us is that suitable fibrations  $\alpha$  of  $P$  give rise to symplectic structures  $\omega$  on  $X(P, L)$ .

**Theorem 3.4** *For any fibration  $\alpha \in H^1(P, \mathbb{Z})$  transverse to  $L$ , there is a symplectic form  $\omega$  on  $X(P, L)$  with*

$$c_1(\omega) = i(e(\alpha|M)).$$

**Proof.** Let  $\alpha = d\pi$  be the closed 1-form representing a fibration  $\pi : P \rightarrow S^1$  transverse to  $L$ .

Pick a closed 2-form  $\beta$  on  $M$  such that  $\beta$  restricts to an area form on each leaf of  $\mathcal{F}$ . (One can construct such a form by representing the monodromy

of the fibration by an area-preserving map.) As observed by Thurston, for  $\epsilon > 0$  sufficiently small, the closed 2-form

$$\omega_0 = \alpha \wedge dt + \epsilon\beta$$

is a symplectic form on  $P \times S^1$ , nowhere vanishing on  $L \times S^1$  [Th1]. (Here  $[dt]$  is the standard 1-form on  $S^1 = \mathbb{R}/\mathbb{Z}$ , and  $\alpha$  and  $\beta$  have been pulled back to the product).

By scaling the Kähler form, we can provide the  $i$ th copy of  $E(1)$  with a symplectic form  $\omega_i$  such that  $\int_F \omega_i = \int_{L_i \times S^1} \omega$ . Then as mentioned above,  $\omega_0$  and  $(\omega_i)$  joined together under fiber-sum to yield a symplectic form  $\omega$  on  $X$ .

Let  $K \rightarrow X$  denote the canonical bundle of  $(X, \omega)$ . We will compute  $c_1(K)$  by constructing a section  $\sigma : X \rightarrow K$ .

Let  $M = P - \mathcal{N}(L)$ . As an oriented  $\mathbb{R}^2$ -bundle,  $K|(M \times S^1)$  is isomorphic to the pullback of  $T\mathcal{F}$  from  $M$ . Let  $s : M \rightarrow T\mathcal{F}$  be a section such that  $s|\partial M$  is inward pointing and nowhere vanishing. Then the zero set of  $s$  is a 1-cycle  $\gamma$  representing the Euler class  $e(\alpha|M) \in H_1(M, \mathbb{R})$ . Pulling back  $s$ , we obtain a section  $\sigma_0 : M \times S^1 \rightarrow K$  with zero set  $\gamma \times S^1$ .

Now consider the 4-manifold  $E(1)' = E(1) - \mathcal{N}(F)$  attached to  $M \times S^1$  along  $T_i \times S^1$ . If we have  $\omega_i(F) > 0$ , then  $K|E(1)'$  is just the pullback of the canonical bundle of  $E(1)$ . Since  $-F$  is a canonical divisor on  $E(1)$ , there is a nowhere vanishing section  $\sigma_i : E(1)' \rightarrow K$ , namely the restriction of a meromorphic 2-form on  $E(1)$  with divisor  $-F$ .

We claim  $\sigma_0$  and  $\sigma_i$  fit together under the gluing identification between  $T_i \times S^1$  and  $F \times S^1$ . To check this, we use the framings to identify  $K|T_i \times S^1$  and  $K|F \times S^1$  with the trivial bundle over  $T^2 \times S^1$ . Under this identification,

$$\sigma_0 : T^2 \times S^1 \rightarrow \mathbb{C}^*$$

is homotopic to the projection  $T^2 \times S^1 \rightarrow S^1 \subset \mathbb{C}^*$ , since the vector field  $s|T_i$  runs along the meridians of  $\partial M$ . Similarly,

$$\sigma_i : T^2 \times S^1 \rightarrow \mathbb{C}^*$$

is homotopic to  $1/\sigma_0$ , because of the simple pole along  $F$ . Since  $T_i \times S^1$  is identified with  $F \times S^1$  using the involution  $(x, t) \sim (x, -t)$  on  $T^2 \times S^1$ , the two sections correspond under gluing.

In the case where we have  $\omega_i(F) < 0$ , both homotopy classes are reversed, so  $\sigma_0$  and  $\sigma_i$  still agree under gluing. Thus  $\sigma_0$  and  $(\sigma_i)$  join together to form a global section  $\sigma : X \rightarrow K$  with no zeros outside  $M \times S^1$ . It follows that  $c_1(X, \omega)$  is Poincaré dual to  $\gamma \times S^1$ ; equivalently, that  $c_1(\omega) = i(\alpha|M)$ . ■



**The Seiberg–Witten polynomial.** A central feature of the fiber-sum  $X = X(P, L)$  is that its Seiberg–Witten polynomial is directly computable.

Assume that  $X$  is simply-connected and  $b_2^+(X) > 1$ . Then the Seiberg–Witten invariant of  $X$  can be regarded as a map

$$\text{SW} : H^2(X, \mathbb{Z}) \rightarrow \mathbb{Z},$$

well-defined up to a sign and vanishing outside a finite set. This information is conveniently packaged as a Laurent polynomial

$$\mathcal{SW}_X = \sum_t \text{SW}(t) \cdot t \in \mathbb{Z}[H^2(X, \mathbb{Z})].$$

**Theorem 3.5** *Suppose  $M$  is the complement of an  $n$ -component link  $L \subset P$ , and  $\pi_1(\partial M)$  normally generates  $\pi_1(M)$ . Then  $X = X(P, L)$  is simply-connected, we have  $b_2^+(X) \geq n$ , and*

$$\mathcal{SW}_X = \pm \sum a_t \cdot i(2t),$$

where  $\Delta_M = \sum a_t \cdot t$  is the symmetrized Alexander polynomial of  $M$ .

**Remarks.** This Theorem was established by Fintushel and Stern in the special case where  $(P, L)$  is obtained by a certain surgery on a link in  $S^3$  [FS2, Thm. 1.9].<sup>1</sup> To obtain the symmetrized Alexander polynomial, one multiplies  $\Delta_K(t)$  by a monomial to arrange that its Newton polygon is centered at the origin. The exponents in the symmetrized polynomial may be half-integral.

**Proof.** To compute  $\mathcal{SW}_X$ , we regard  $X$  as the union of manifolds  $X_0 = M \times S^1$  and  $X_i = E(1) - \mathcal{N}(F)$ ,  $i = 1, \dots, n$ , glued together along their boundary. For such manifolds one can define a *relative* Seiberg–Witten polynomial  $\mathcal{SW}_{X_i} \in \mathbb{Z}[H^2(X_i, \partial X_i; \mathbb{Z})]$ , such that

$$\mathcal{SW}_X = \mathcal{SW}_{X_0} \cdot \mathcal{SW}_{X_1} \cdots \mathcal{SW}_{X_n},$$

using the natural map  $H^2(X_i, \partial X_i) \rightarrow H^2(X)$  to compute the product. For this gluing formula, developed by Morgan, Mrowka, Szabo and Taubes, see [FS2, Thm. 2.2] and [Ta].

Now for each  $X_i = E(1) - \mathcal{N}(F)$ , the relative polynomial is simply 1. To see this, just apply the product formula above to the K3 surface

---

<sup>1</sup>Note: contrary to [FS2, p. 371]: the cohomology classes  $[T_j]$  in their formula for  $\mathcal{SW}_X$  are always linearly independent in  $H^2(X, \mathbb{R})$ , by Proposition 3.2 above.

$Z = E(1) \#_F E(1)$ , which satisfies  $\text{SW}_Z = 1$ . (This well-known property of K3 surfaces follows, for example, from equations (4.17) and (4.20) in Witten's original paper [Wit].)

Thus we have  $\mathcal{SW}_X = \mathcal{SW}_{X_0} = \mathcal{SW}_{M \times S^1}$ . Finally the Seiberg-Witten polynomial for  $M \times S^1$  is given in terms of  $\Delta_M$  by the main result of [MeT], yielding the formula for  $\mathcal{SW}_X$  above.

To see  $\pi_1(X) = \{1\}$  and  $b_2^+(X) \geq n$ , apply Proposition 3.1 and Corollary 3.3 above.  $\blacksquare$

**Proof of Theorem 1.1.** Using the Seiberg–Witten invariants to control the action of  $\text{Diff}(X)$ , it is now easy to give an example of a simply-connected 4-manifold  $X$  with inequivalent symplectic forms.

For a concrete example, let  $X = X(T^3, L)$  for the 4-component link  $L \subset T^3$  studied in the preceding section, and choose any framing of  $L$ . As we have seen, the link-complement  $M = T^3 - \mathcal{N}(L)$  is homeomorphic to the exterior  $S^3 - \mathcal{N}(K)$  of the Borromean rings plus axis. In particular,  $\pi_1(M)$  is the normal closure of  $\pi_1(\partial M)$ , so  $X$  is simply-connected and we have  $b_2^+(X) \geq 4$ .

Let  $m_i, i = 1, \dots, 4$  be the basis for  $H_1(M, \mathbb{Z})$  coming from the meridians of  $K \subset S^3$ . Then the classes  $t_i = i(m_i)$  form a basis for  $i(H_1(M, \mathbb{Z})) \subset H^2(X, \mathbb{Z})$ . By Theorem 3.5, we have:

*The Seiberg–Witten polynomial of  $X$  is given by*

$$\mathcal{SW}_X = \Delta_M(t_1^2, t_2^2, t_3^3, t_4^2),$$

*where  $\Delta_M(x, y, z, t)$  is given by Lemma 2.4.*

In particular, the Newton polygons satisfy  $N(\mathcal{SW}_X) = 2i(N(\Delta_M))$ .

Now identify  $H_1(T^3, \mathbb{R})$  with the subspace of  $H_1(M, \mathbb{R})$  spanned by  $(m_1, m_2, m_3)$ , and let

$$N_0 = N(\Delta_M) \cap H_1(T^3, \mathbb{R}).$$

As we have seen before, any vertex  $v$  of  $N_0$  is dual to a fibered face  $F$  of the Thurston norm on  $H^1(M, \mathbb{R})$ ; indeed,  $v$  is dual to a fibration pulled back from  $T^3$ . All fibrations  $\phi$  in the cone over  $F$  have the same Euler class  $e$ , which satisfies

$$\|\phi\|_T = 2\phi(v) = -\phi(e);$$

thus  $e = -2v$ .

By Theorem 3.4, the vertex

$$i(e) = i(-2v) \in 2i(N_0)$$

is the first Chern class of a symplectic structure on  $X$ . Since  $v \in N_0$  was an arbitrary vertex, we have:

*Every vertex of  $2i(N_0) \subset N(\mathcal{SW}_X)$  is the first Chern class of a symplectic structure on  $X$ .*

Now pick a pair combinatorially distinct vertices

$$v_0, v_1 \in 2i(N_0) \subset N(\mathcal{SW}_X).$$

More precisely, referring to Figure 3 (top), we see  $2i(N_0)$  has vertices of degrees 3 and 4; choose one of each type. Then  $v_0$  and  $v_1$  have degrees 5 and 6 as vertices of  $N(\mathcal{SW}_X)$ , since

$$N(\mathcal{SW}_X) = 2i(N_0) + [-2, 2] \cdot t_4$$

is simply the suspension of  $2i(N_0)$ . As a consequence, no automorphism of  $H^2(X, \mathbb{R})$  stabilizing  $N(\mathcal{SW}_X)$  can transport  $v_0$  to  $v_1$ .

To complete the proof, choose symplectic forms on  $X$  with  $c_1(\omega_0) = v_0$  and  $c_1(\omega_1) = v_1$ . Then the Chern classes of  $\omega_0$  and  $\omega_1$  lie in distinct orbits for the action of  $\text{Diff}(X)$  on  $H^2(X, \mathbb{R})$ , since diffeomorphisms preserve the Newton polygon of the Seiberg–Witten polynomial. In particular,  $\omega_0$  and  $\omega_1$  are inequivalent symplectic forms on  $X$ . ■

**Question.** Could it be that  $\text{Diff}(X)$  actually preserves the submanifold  $M \times S^1 \subset X$  up to isotopy?

**Further example: skirting gauge theory.** To conclude, we sketch an *elementary* example of a 4-manifold  $X$  carrying a pair of inequivalent symplectic forms — but with  $\pi_1(X) \neq 1$ . By elementary, we mean the proof does not use the Seiberg–Witten invariants; instead, it uses the fundamental group.

To construct the example, simply let  $X = N \times S^1$ , where  $N$  is the closed 3-manifold discussed at the end of §2.

By considering  $N$  as a covering of  $T^3$  with a  $\mathbb{Z}/2$ -orbifold locus along  $L$ , one can show that  $\pi_1(N)$  has trivial center. It follows that  $\pi_1(S^1)$  is the center of  $\pi_1(X)$ , and thus the projection

$$\pi_1(X) \rightarrow \pi_1(N)$$

is canonical. In particular, every diffeomorphism of  $X$  induces an automorphism of  $\pi_1(N)$ .

Now let  $\alpha_0, \alpha_1$  be fibrations of  $N$  whose Euler classes are in different orbits for the action of  $\text{Aut}(\pi_1(N))$  on  $H_1(N, \mathbb{Z})$ . (These classes exist as before, because the Alexander polynomial is functorially determined by  $\pi_1(N)$ , and hence preserved by automorphisms.) Then the Euler classes  $e(\alpha_0), e(\alpha_1)$  lie in disjoint orbits for the action of  $\text{Diff}(X)$  on  $H_1(N) = H_1(X)/H_1(S^1)$ .

Now as we have seen above, each  $\alpha_i$  gives a symplectic form  $\omega_i$  on  $X$  with  $c_1(\omega_i)$  dual to  $e(\alpha_i) \times S^1$ . Since the Euler classes lie in disjoint orbits for the action of  $\text{Diff}(X)$ , so do these Chern classes. In particular,  $\omega_0$  and  $\omega_1$  are inequivalent symplectic forms on  $X$ . ■

## References

- [CF] R. H. Crowell and R. H. Fox. *Introduction to Knot Theory*. Springer-Verlag, 1977.
- [FS1] R. Fintushel and R. Stern. Constructions of smooth 4-manifolds. In *Proceedings of the International Congress of Mathematicians, Vol. II (Berlin, 1998)*, pages 443–452. Doc. Math., 1998.
- [FS2] R. Fintushel and R. Stern. Knots, links and 4-manifolds. *Invent. math.* **134**(1998), 363–400.
- [FS3] R. Fintushel and R. Stern. Symplectic structures in a fixed homology class. *In preparation*.
- [Fox] R. H. Fox. Free differential calculus I, II, III. *Annals of Math.* **57**, **59**, **64**(1953, 54, 56), 547–560, 196–210, 407–419.
- [FQ] M. Freedman and F. Quinn. *Topology of 4-manifolds*. Princeton University Press, 1990.
- [Fr] D. Fried. Fibrations over  $S^1$  with pseudo-Anosov monodromy. In *Travaux de Thurston sur les surfaces*, pages 251–265. Astérisque, volume 66–67, 1979.
- [Go] R. Gompf. A new construction of symplectic manifolds. *Ann. Math.* **142**(1995), 527–595.
- [GS] R. Gompf and A. Stipsicz. *4-Manifolds and Kirby Calculus*. Amer. Math. Soc., 1999.

- [HKK] J. Harer, A. Kas, and R. Kirby. *Handlebody Decompositions of Complex Surfaces*. Mem. Amer. Math. Soc., No. 350, 1986.
- [Kr1] P. Kronheimer. Embedded surfaces and gauge theory in three and four dimensions. In *Surveys in differential geometry, Vol. III (Cambridge, MA, 1996)*, pages 243–298. Int. Press, 1998.
- [Kr2] P. Kronheimer. Minimal genus in  $S^1 \times M^3$ . *Invent. math.* **135**(1999), 45–61.
- [KM] P. Kronheimer and T. Mrowka. Scalar curvature and the Thurston norm. *Math. Res. Lett.* **4**(1997), 931–937.
- [MW] J. McCarthy and J. Wolfson. Symplectic normal connect sum. *Topology* **33**(1994), 729–764.
- [Mc1] C. McMullen. Polynomial invariants for fibered 3-manifolds and Teichmüller geodesics for foliations. *Ann. scient. Éc. Norm. Sup.* **33**(2000), 519–560.
- [Mc2] C. McMullen. The Alexander polynomial of a 3-manifold and the Thurston norm on cohomology. *Ann. scient. Éc. Norm. Sup.* **35**(2002), 153–172.
- [MeT] G. Meng and C. H. Taubes.  $\underline{SW}$  = Milnor torsion. *Math. Res. Lett.* **3**(1996), 661–674.
- [Ta] C. Taubes. The Seiberg-Witten invariants and 4-manifolds with essential tori. *In preparation*.
- [Th1] W. P. Thurston. Some simple examples of symplectic manifolds. *Proc. Amer. Math. Soc.* **55**(1976), 467–468.
- [Th2] W. P. Thurston. A norm for the homology of 3-manifolds. Mem. Amer. Math. Soc., No. 339, pages 99–130, 1986.
- [Vi] S. Vidussi. The Alexander norm is smaller than the Thurston norm: a Seiberg-Witten proof. *École Polytechnique Preprint 99-6*.
- [Wit] E. Witten. Monopoles and four-manifolds. *Math. Res. Letters* **1**(1994), 769–796.

MATHEMATICS DEPARTMENT  
HARVARD UNIVERSITY  
1 OXFORD ST  
CAMBRIDGE, MA 02138-2901